

NOTICE D'INSTALLATION

INSTALLATION INSTRUCTIONS

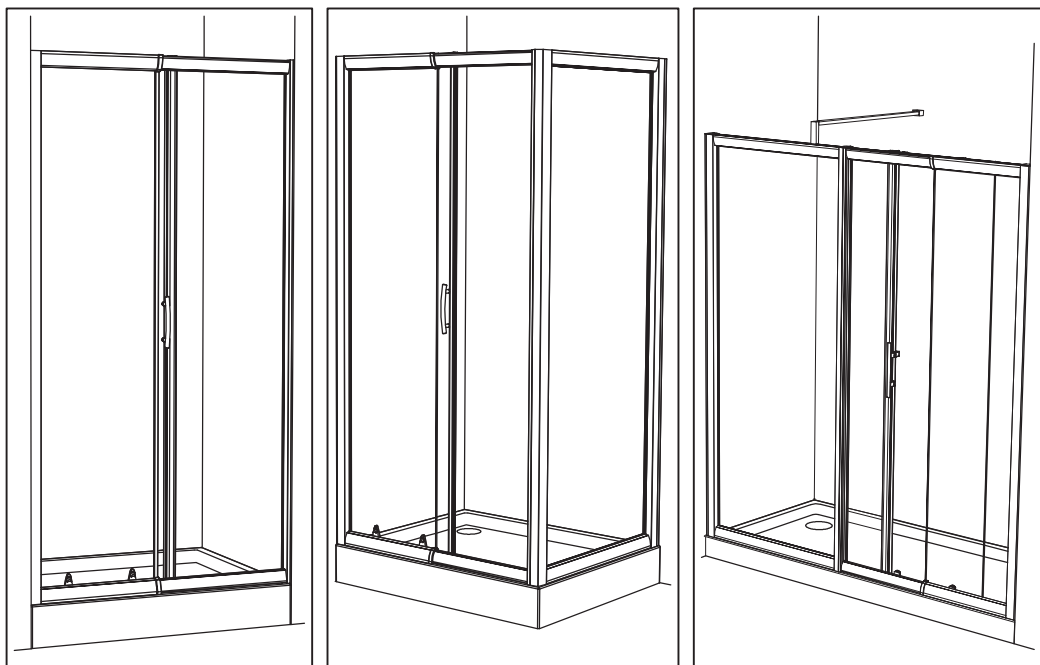

DES591I

IMPORTANT :

- Le receveur sur lequel vous allez poser la paroi doit être parfaitement lisse et dégraissé. Les montages sans receveur directement sur sol carrelé (à "l'italienne"), ne sont donc pas préconisés pour un montage sans silicone.
- Les murs ne doivent pas avoir de reliefs supérieurs à 2 mm (joint de carrelage ou de décor) afin que les joints d'étanchéité puissent épouser la forme du mur.
- L'utilisation de jets d'hydromassage peut réduire l'efficacité de l'étanchéité sans silicone si ceux-ci sont trop puissants.

IMPORTANT :

- The shower tray should be perfectly level from left to right and front to back as well as thoroughly clean and dry.
- The depth of the grout gap between wall tiles should not exceed 2mm.
- The use of hydromassage jets can reduce efficiency of silicone free sealing if they are too powerful.

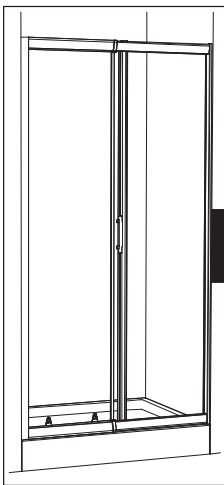

INSTALLATION EN NICHE :
INSTALLATION BETWEEN WALLS :
page 4

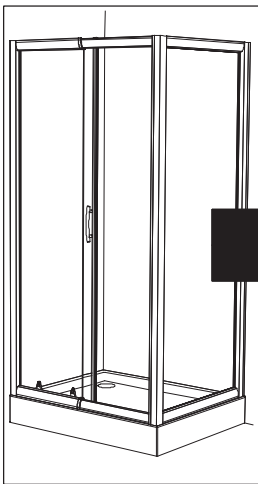





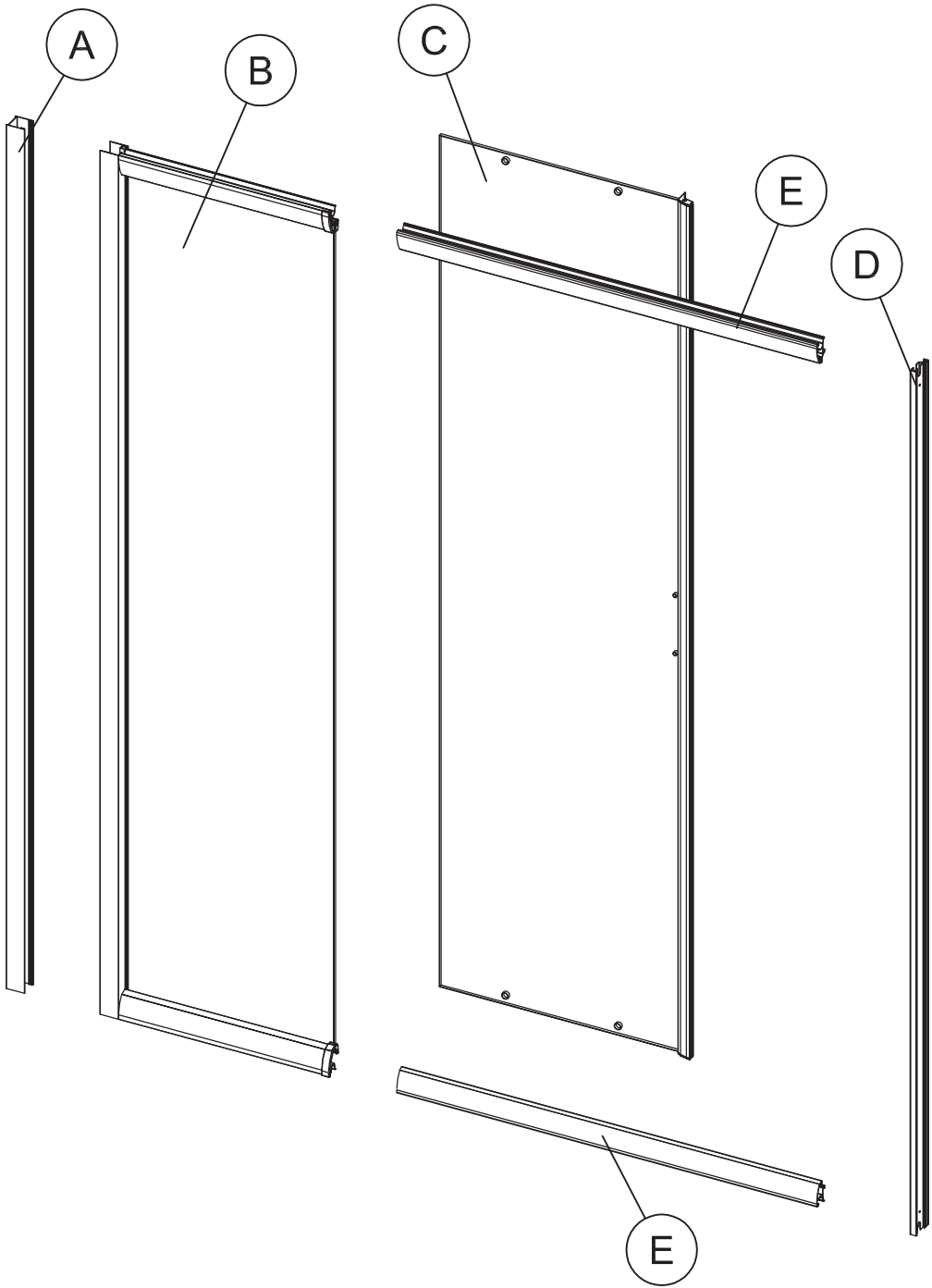

INSTALLATION EN ANGLE AVEC UN FIXE :
ANGLE INSTALLATION WITH A FIXED PANEL :
page 24

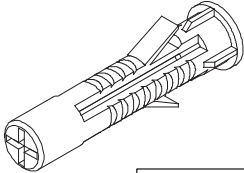
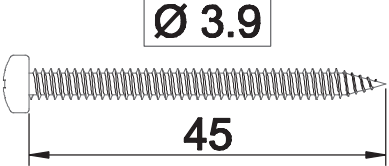

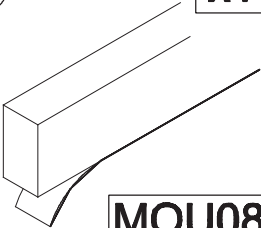
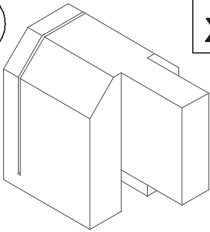
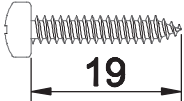
INSTALLATION ALIGNÉE AVEC UN FIXE :
ALIGNED INSTALLATION WITH A FIXED PANEL :
page 46

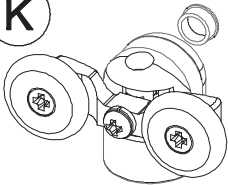
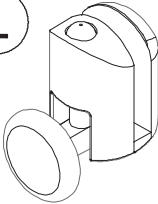
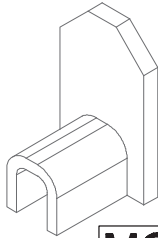
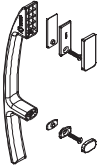
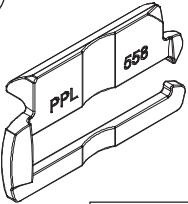
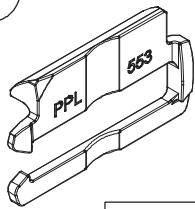
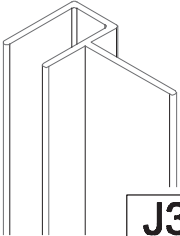
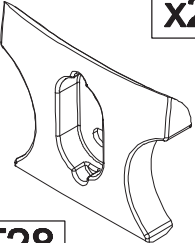
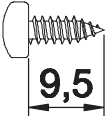

F  CHE02 x8	G  $\text{Ø } 3.9$ 45  1 = 1 VIS17 x8	
H  MOU08 x1	I  MOU03 x1	J  $\text{Ø } 3.5$ 19  1 = 1 VIS3.5x19 x7
K  BLC=ROU12 CHR=ROU19 x2	L  BLC=ROU22 CHR=ROU23 x2	M  MOU04 x1
N  PGN39+SET85 x1	O  PPL558 x1	P  PPL553 x1
Q  J365 x1	R  BUT28 x2	S  $\text{Ø } 3.5$ 9,5  1 = 1 VIS01 x4

Les quantités données sont les quantités utiles au montage. Les sachets fournis contiennent des pièces supplémentaires.
The quantities given are what are required for the installation. There may be some surplus parts in the package provided.

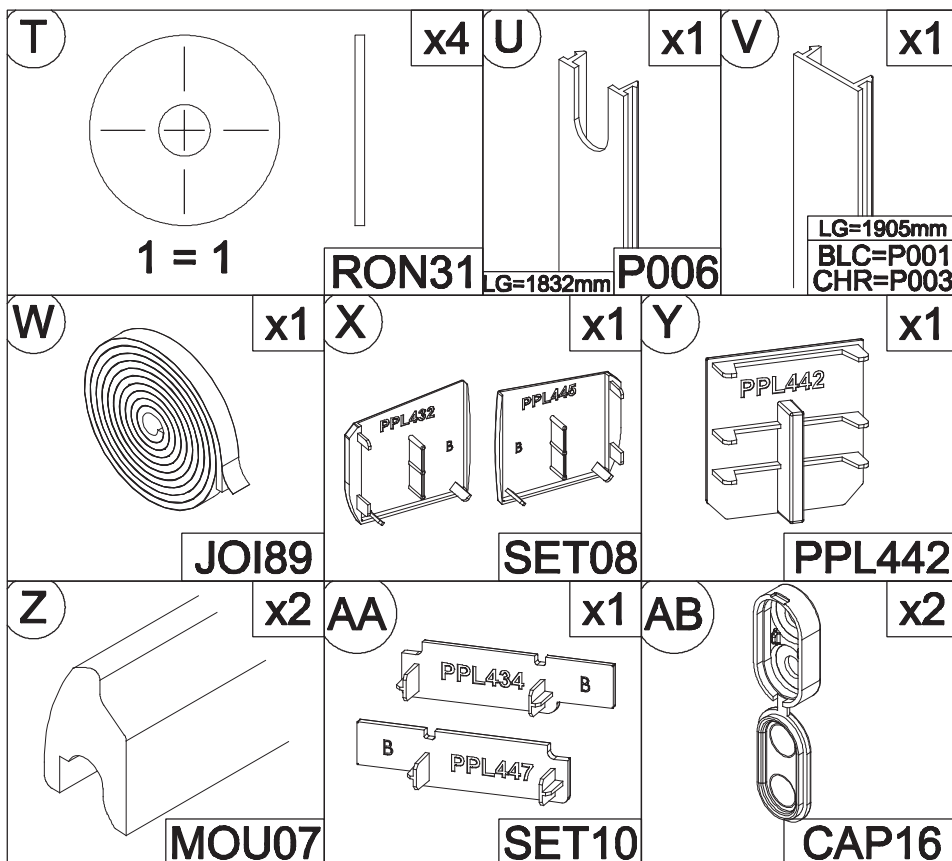

Les quantités données sont les quantités utiles au montage. Les sachets fournis contiennent des pièces supplémentaires.
The quantities given are what are required for the installation. There may be some surplus parts in the package provided.

MATERIEL NECESSAIRE - TOOLS REQUIRED

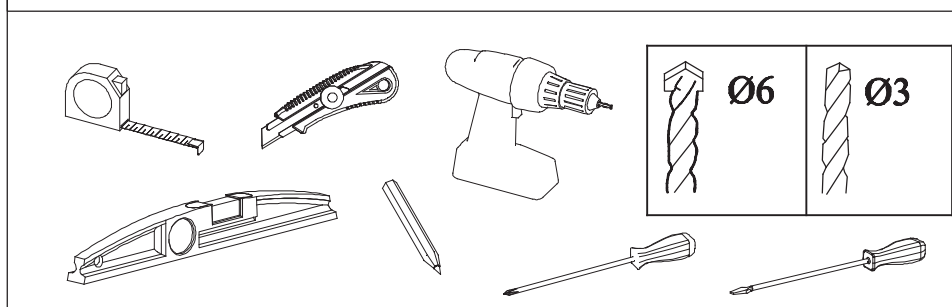

AVANT L'INSTALLATION DE VOTRE PARI, NETTOYER LE RECEVEUR AVEC UN PRODUIT DÉGRAISSANT.

BEFORE INSTALLING YOUR SHOWER ENCLOSURE PLEASE ENSURE THAT THE TRAY SURFACES HAVE BEEN THOROUGHLY CLEANED AND ARE FREE FROM GREASE.

Paroi réversible pour ouverture droite et gauche.
Reversible enclosure for right or left opening.

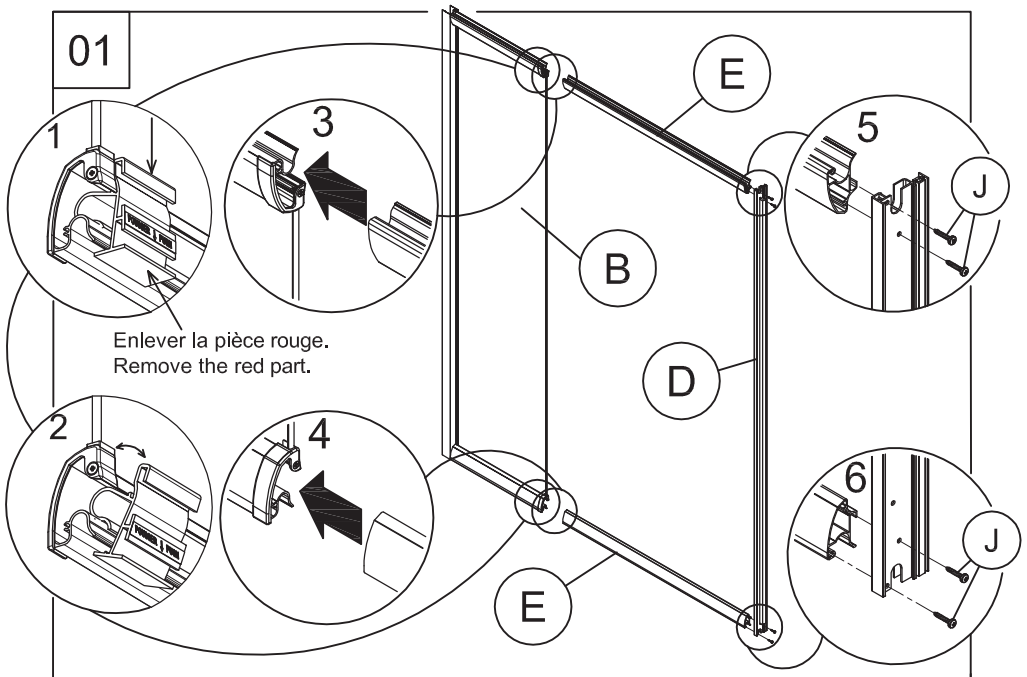
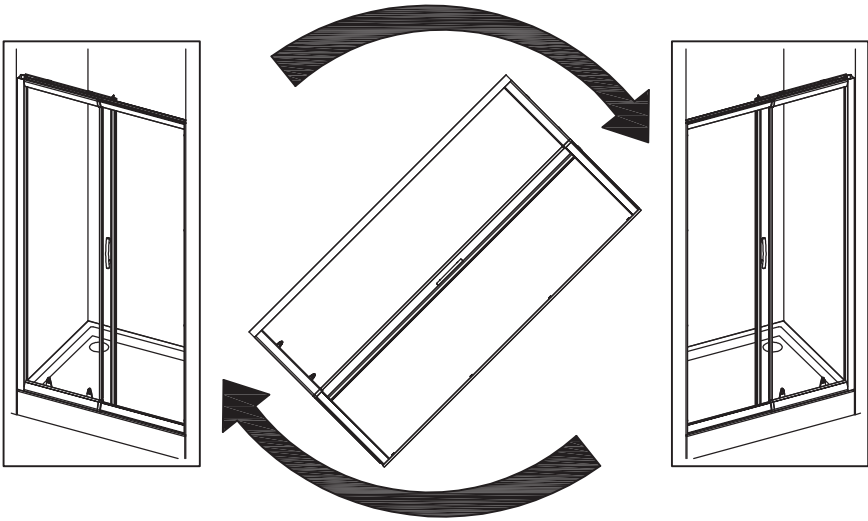

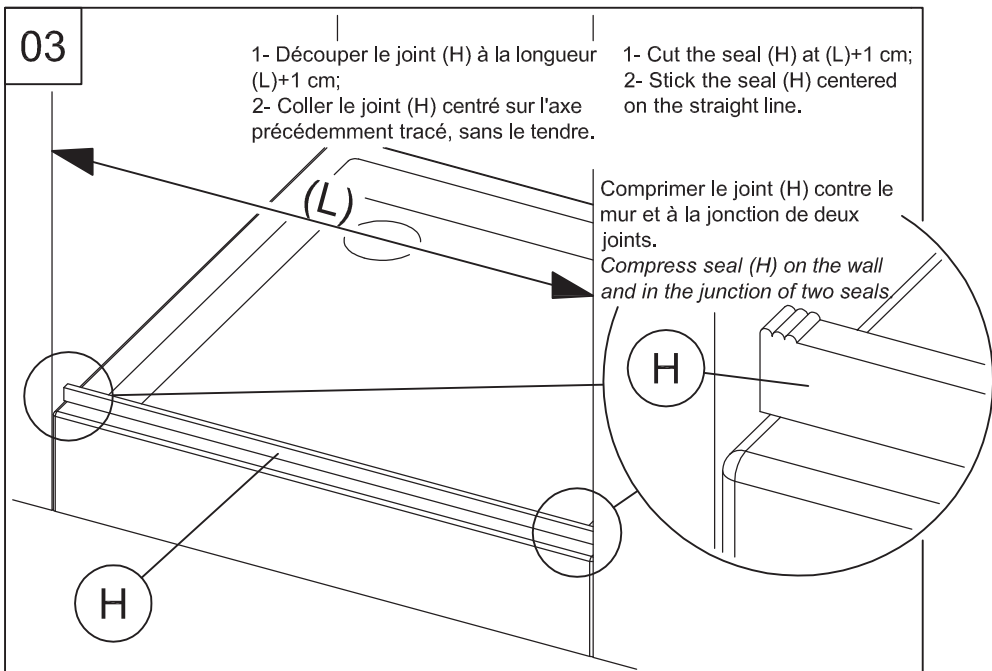
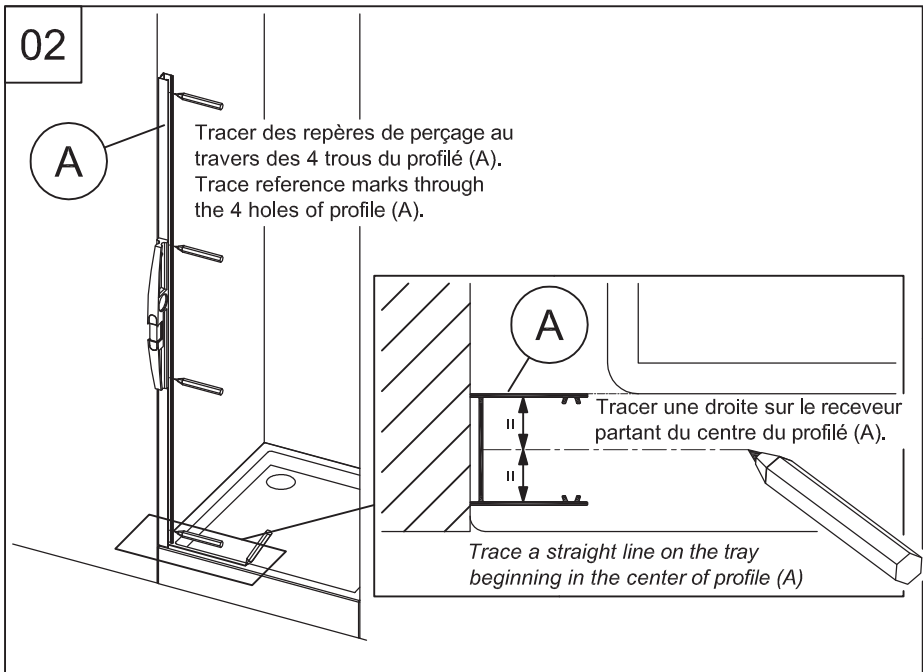

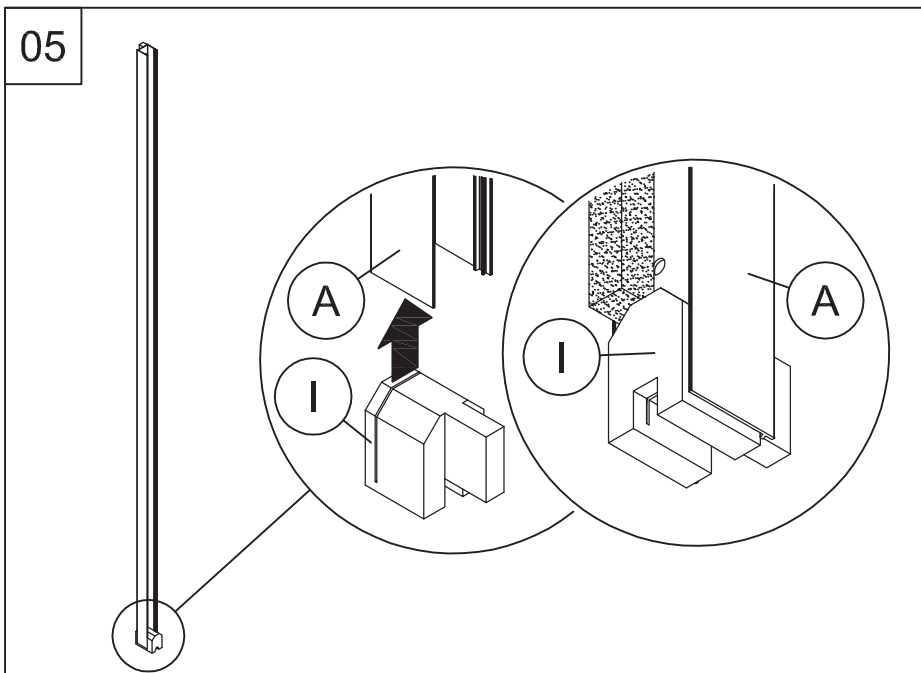
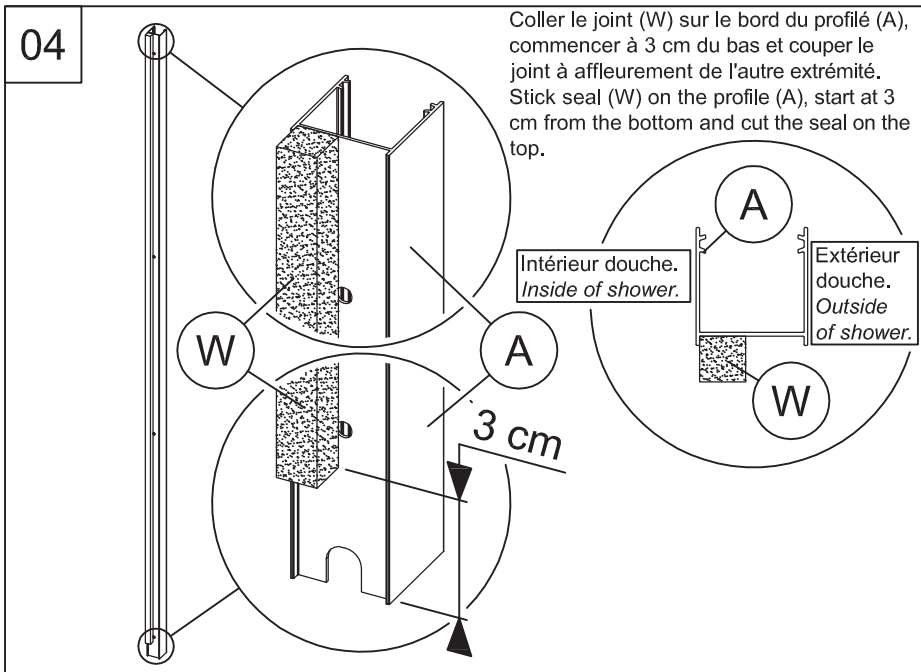

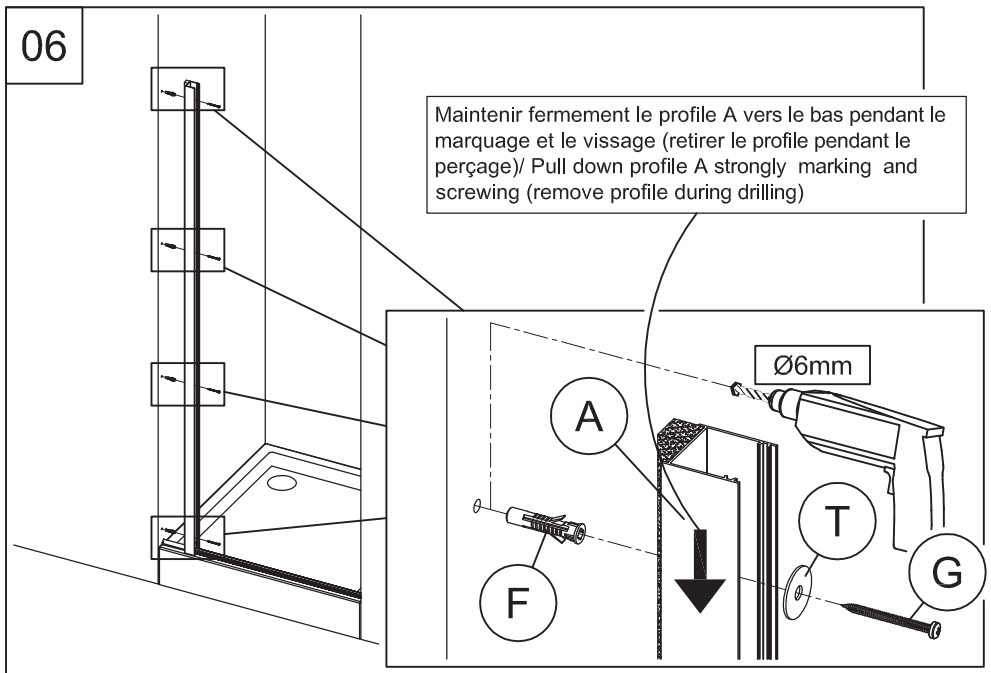

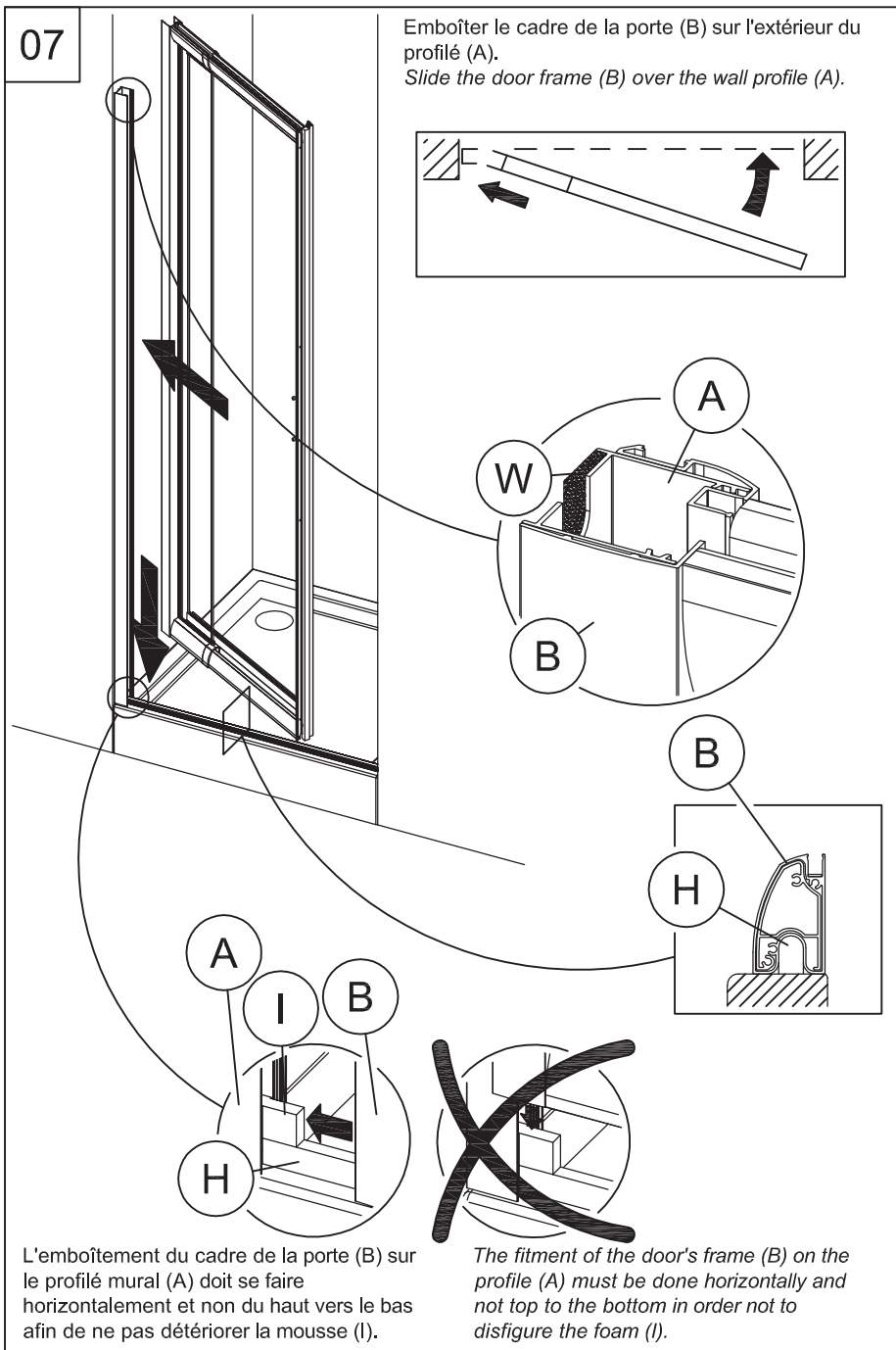

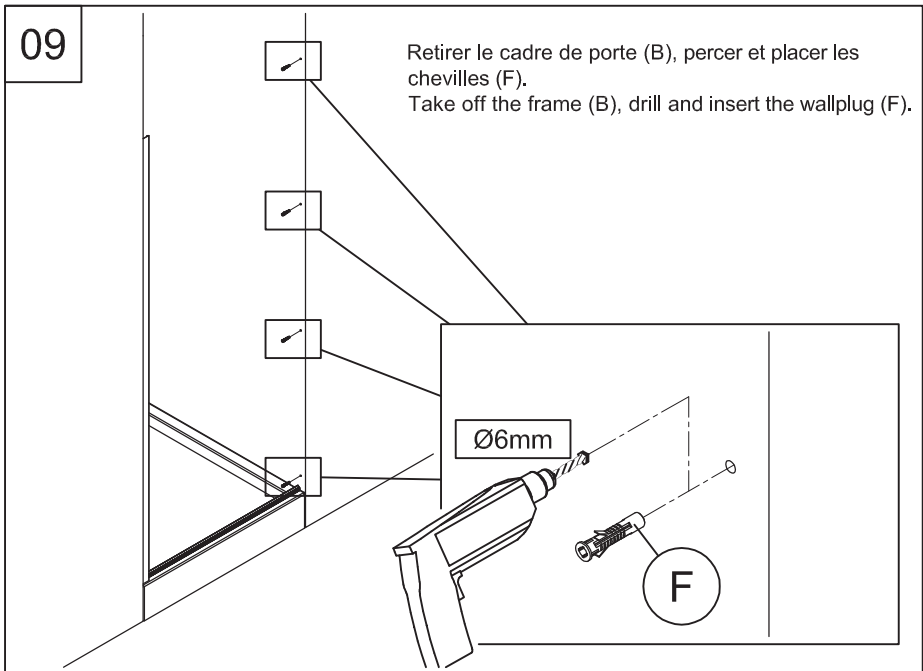
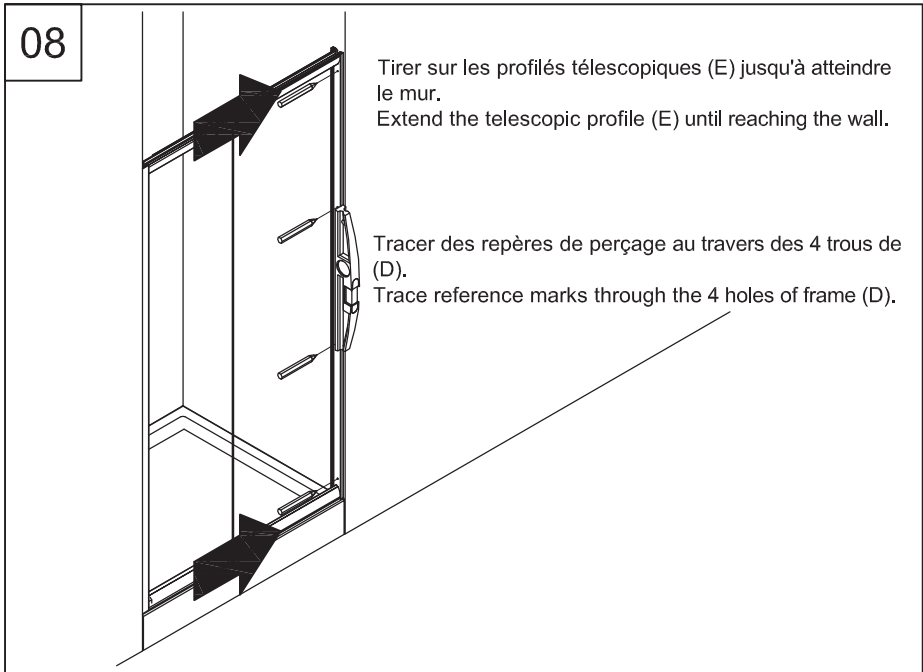

10

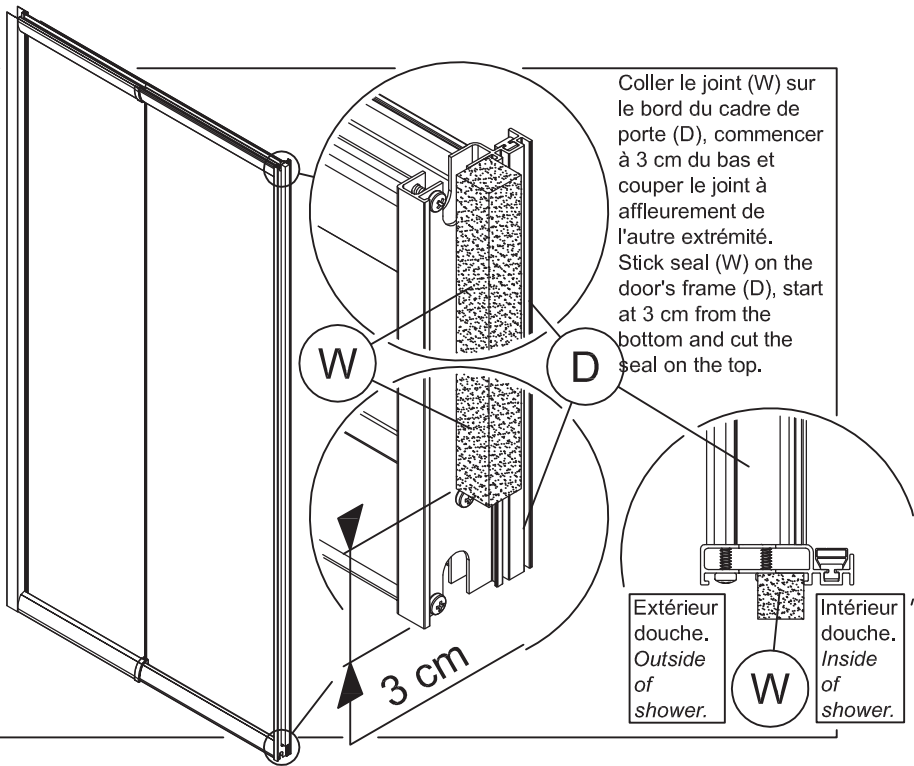

11

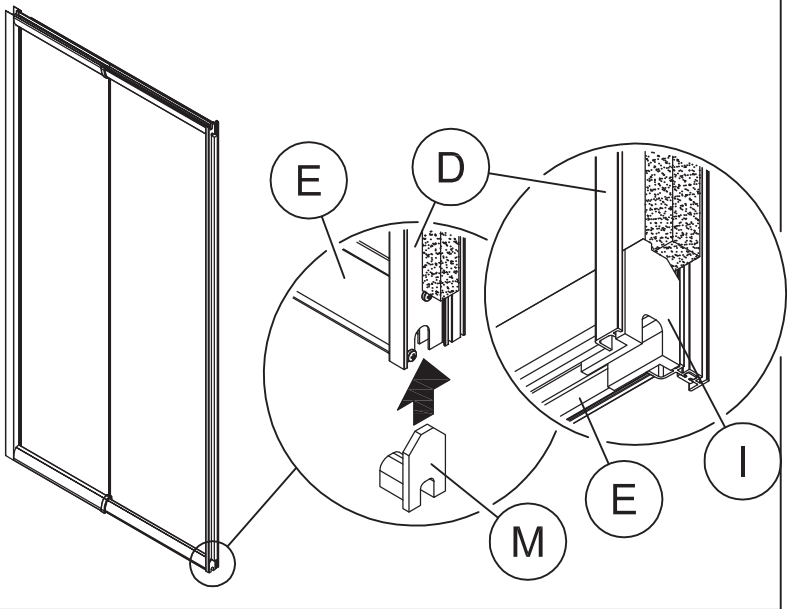

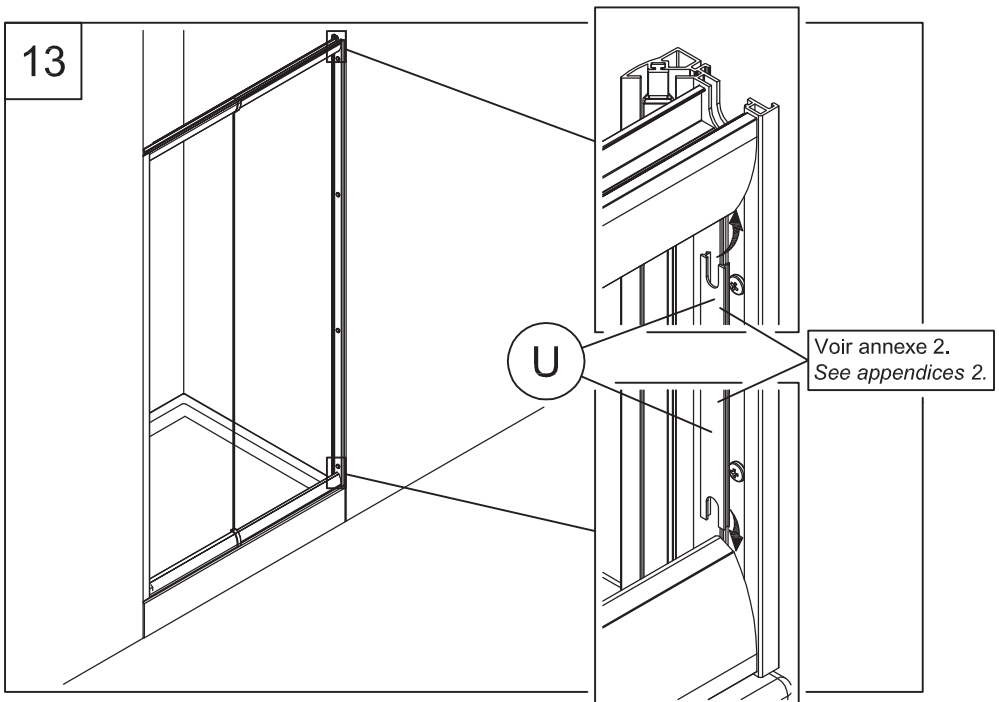
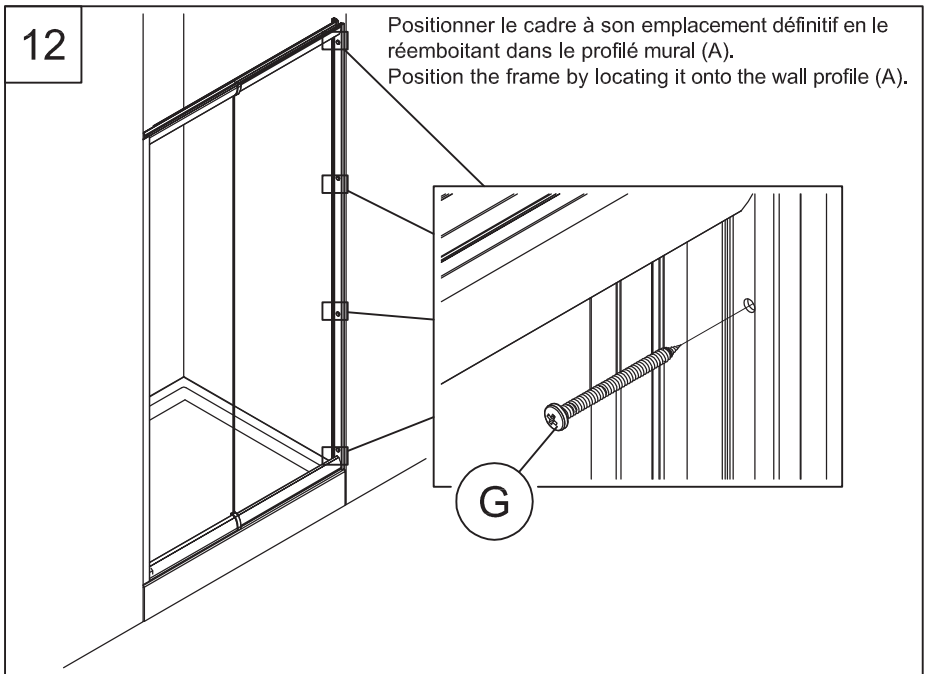

14

Vérifier l'aplomb du cadre, contrepercer et fixer.
Check the frame is vertical, drill and fix.

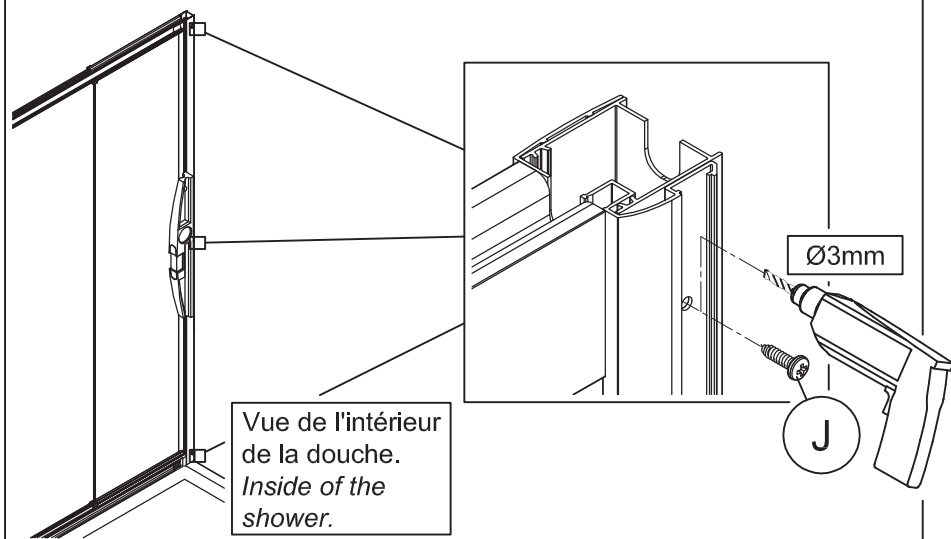

15

Ajuster (V) si nécessaire.
Adjust (V) if necessary.

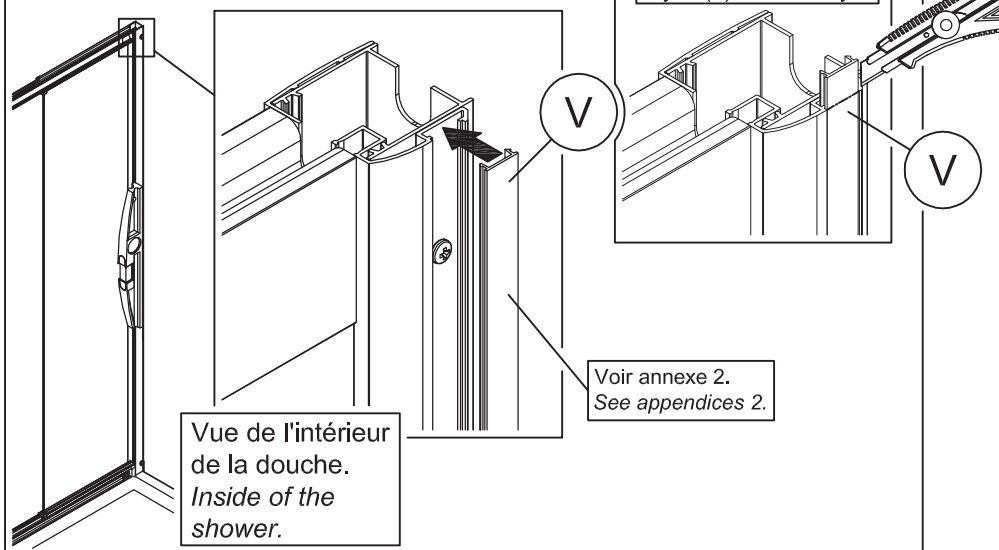

16

Positionner le joint (Q) sur le verre fixe.
Attach the seal (Q) to the fixed panel.

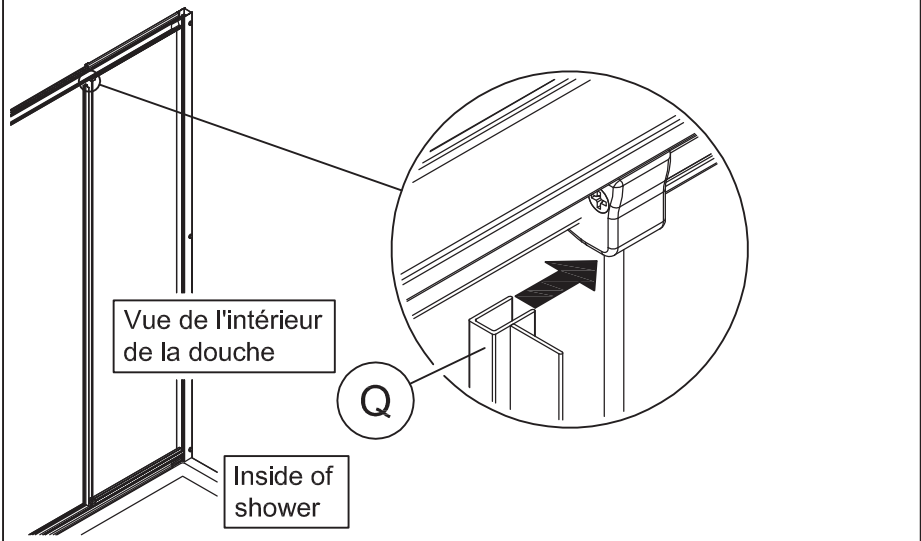

17

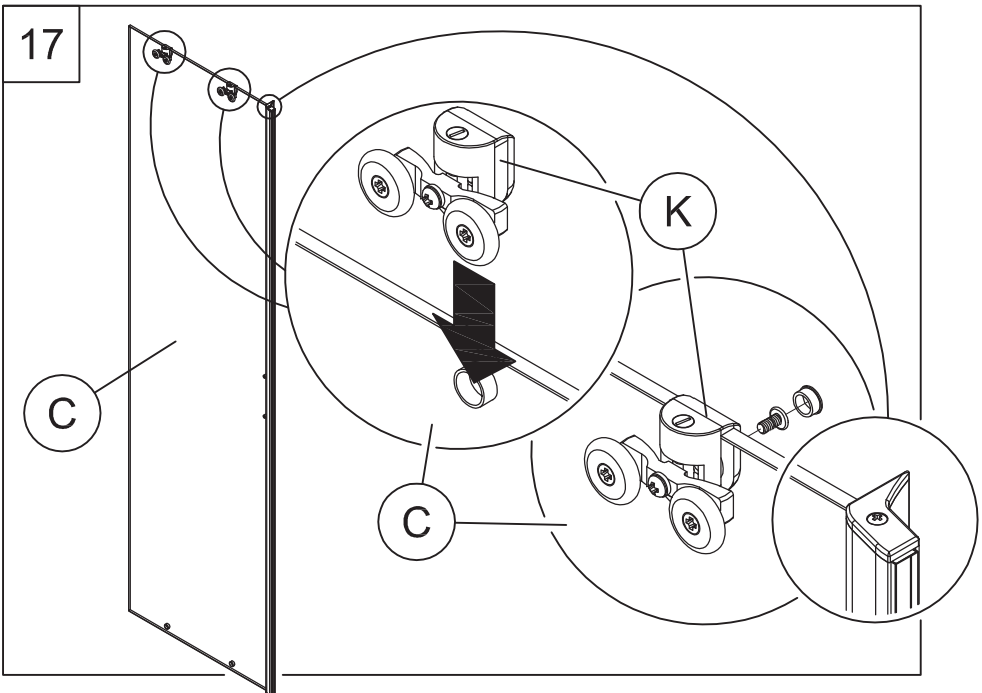

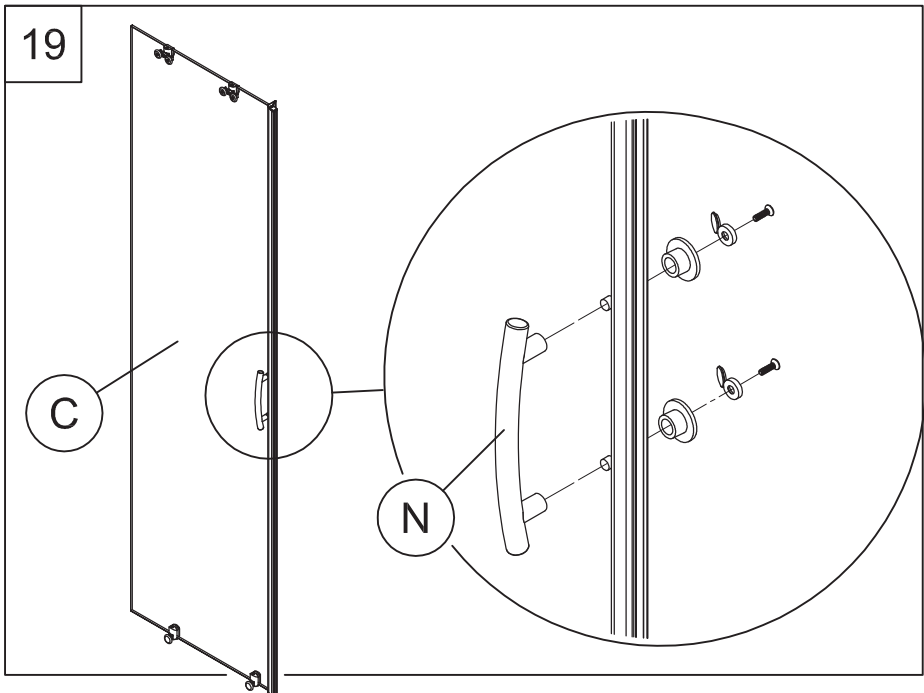
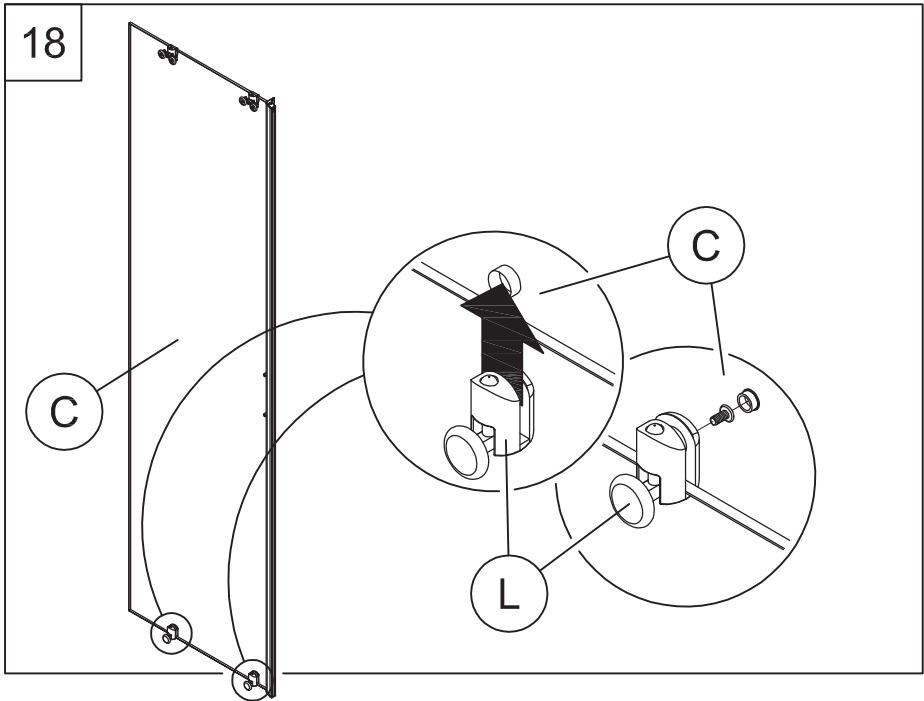

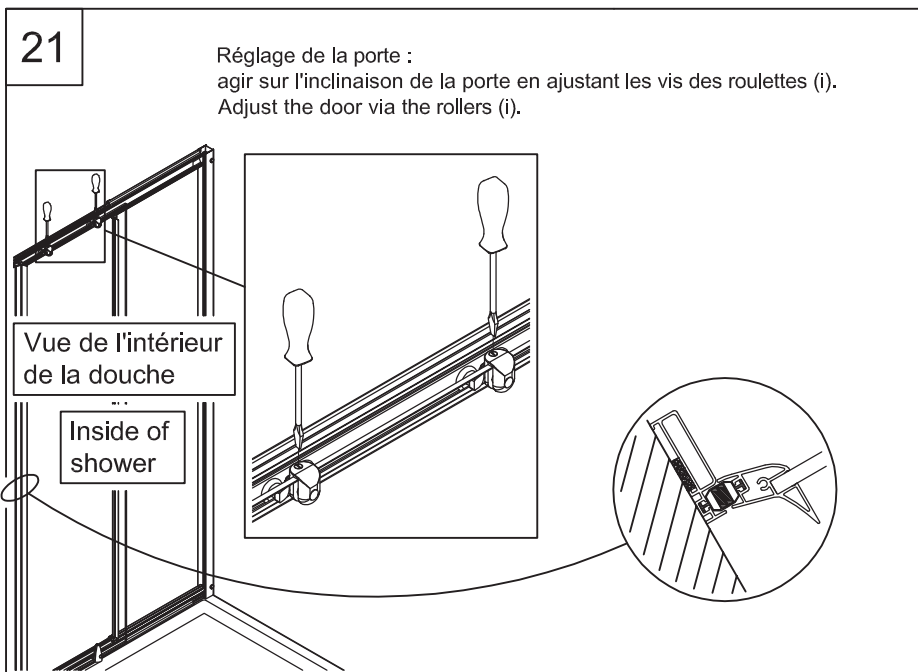
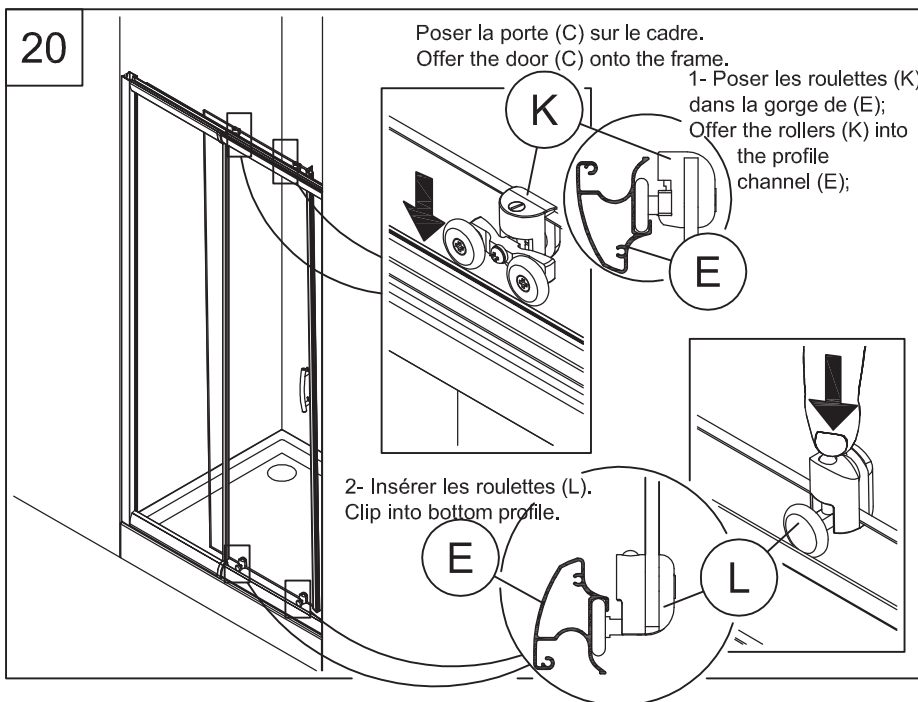

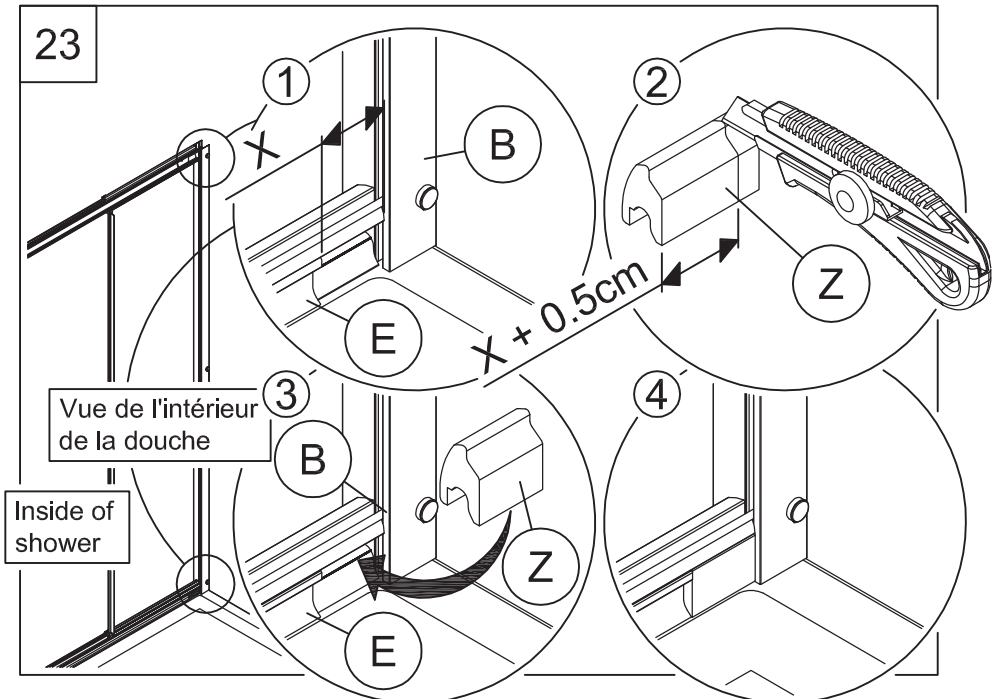
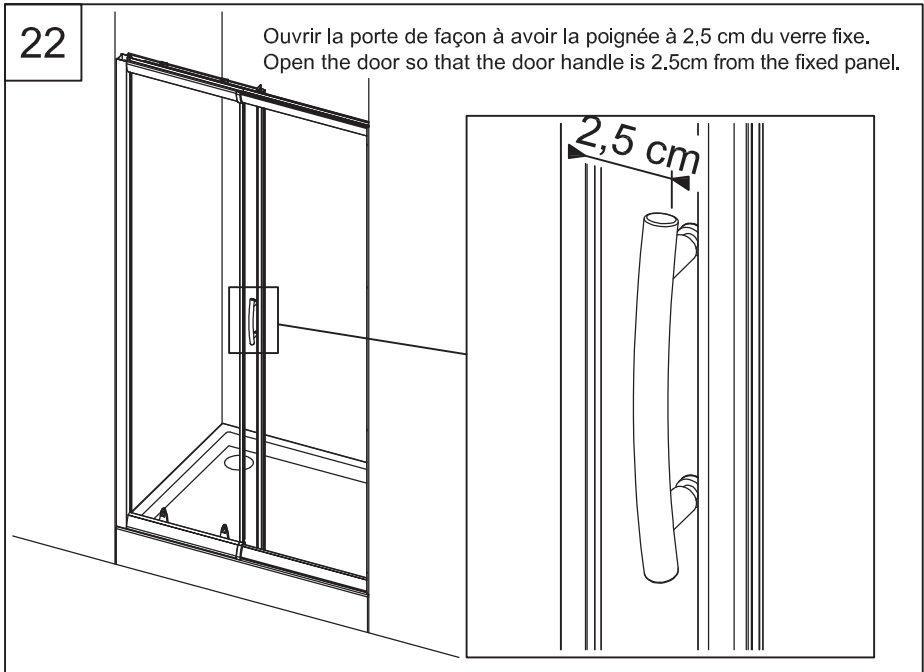

24

Fixer les butées (R) afin :
 - de bloquer l'ouverture de la porte dans la position
 précédemment réglée,
 - et de bloquer les extensions (E).
 Fix the door stops so that it opens correctly.

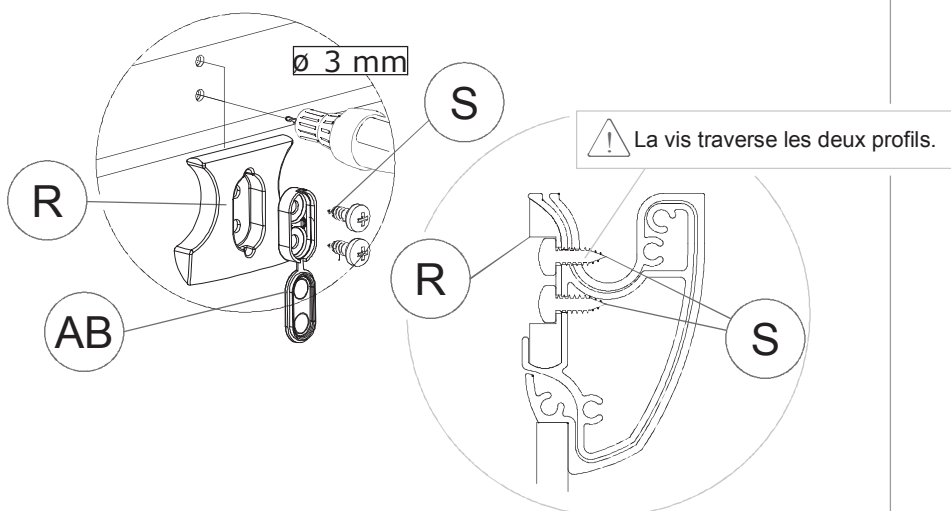
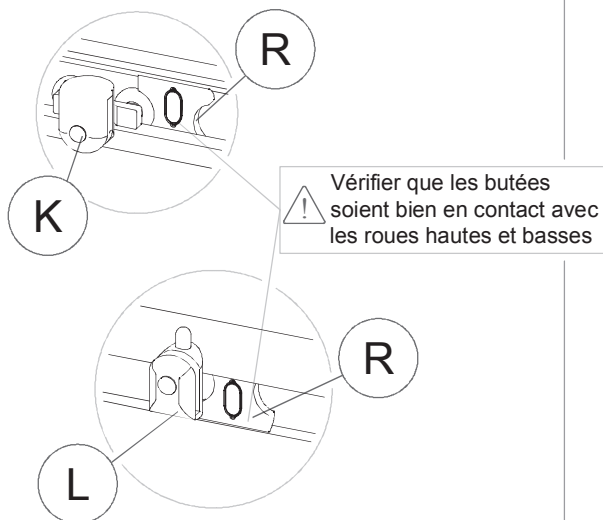
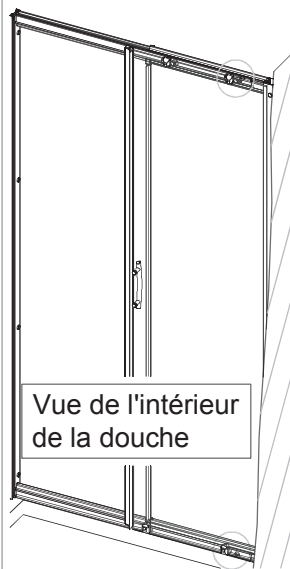

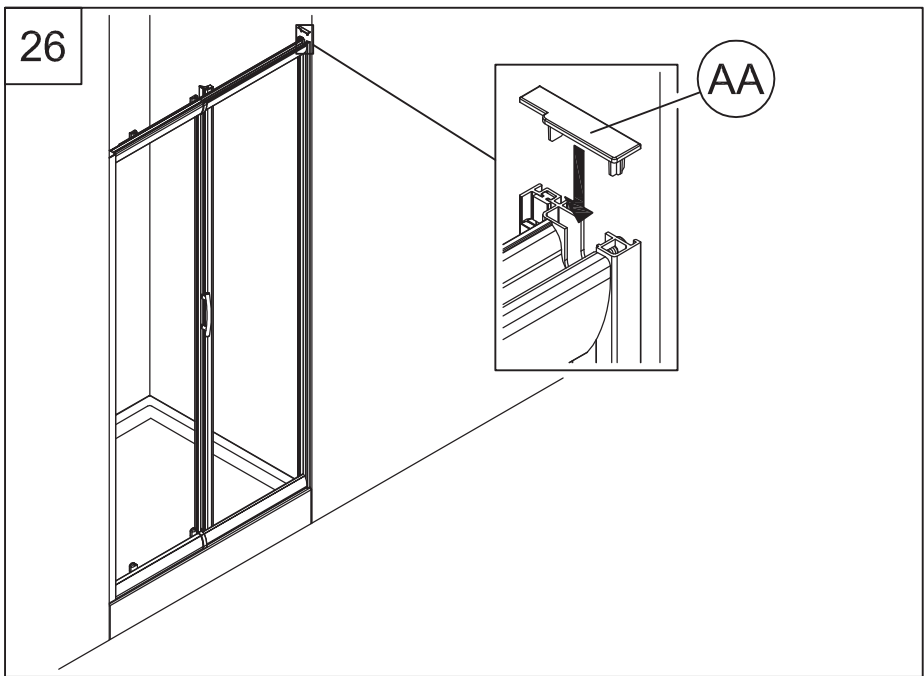
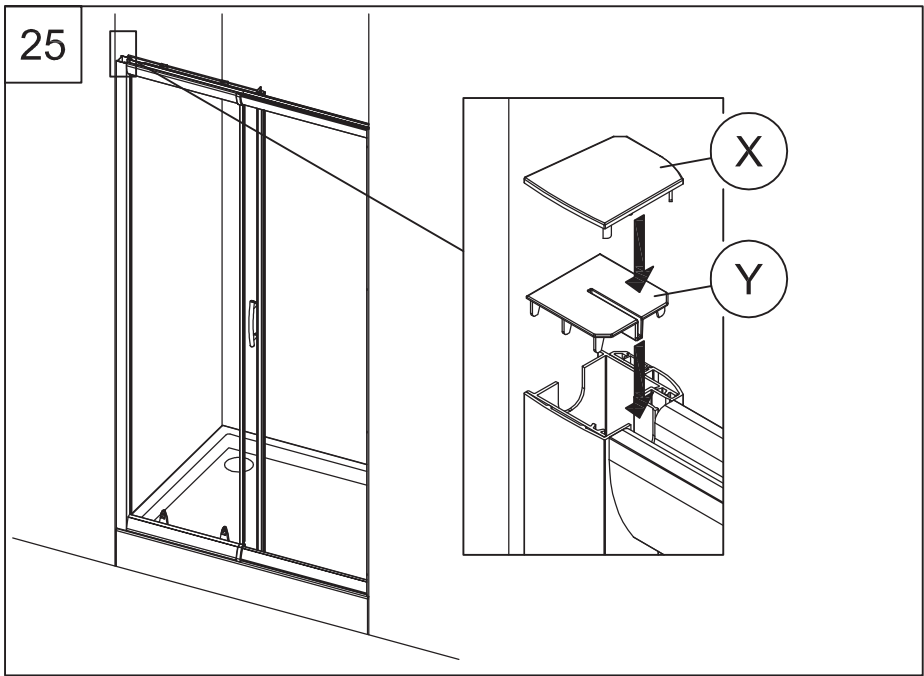

27

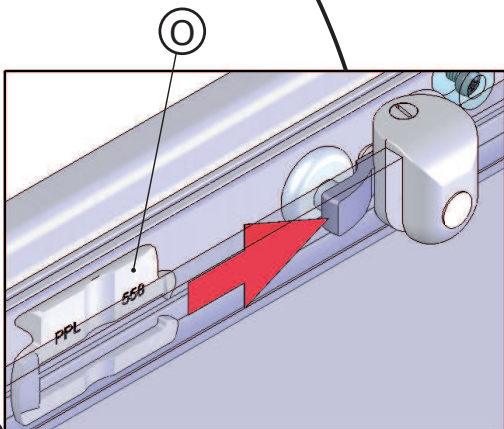



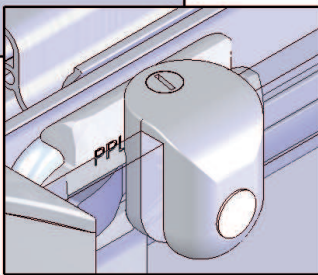
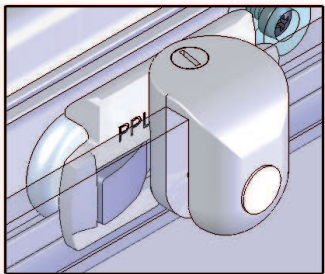
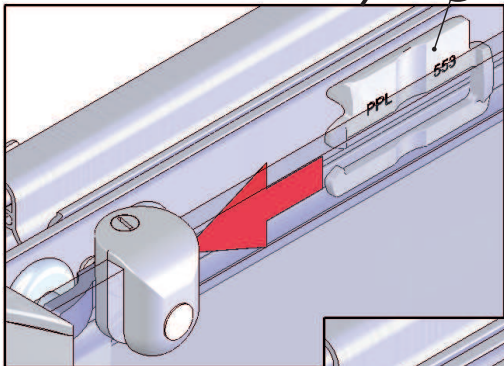

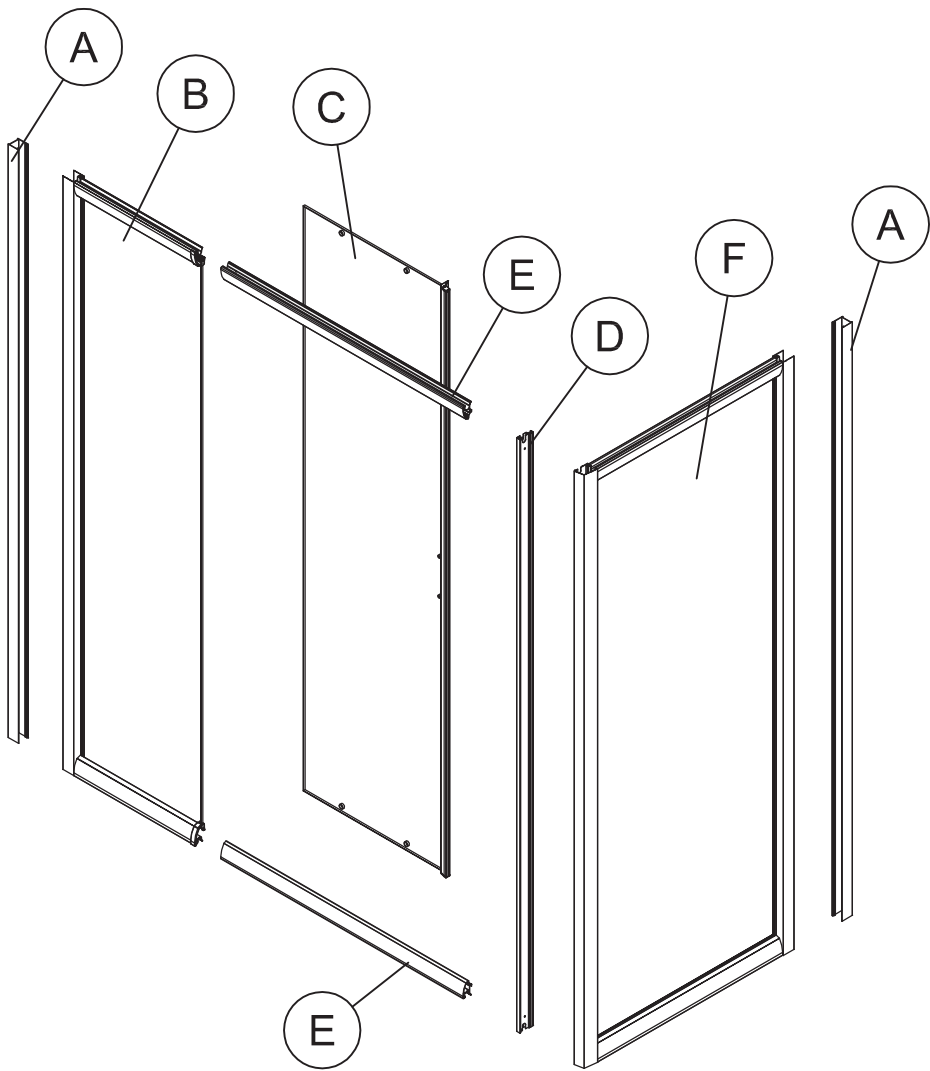
P

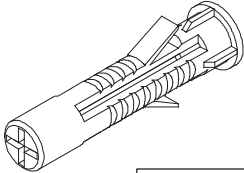
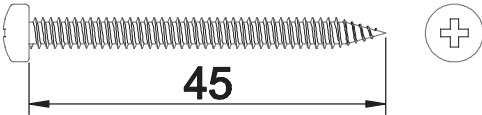
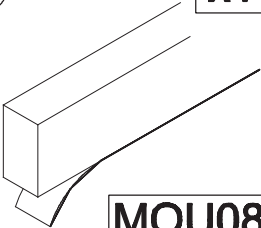
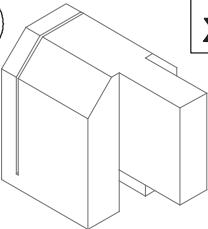
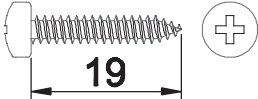
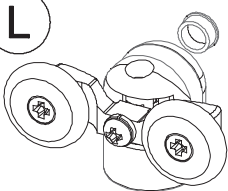
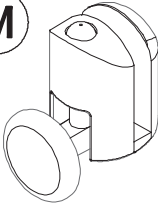
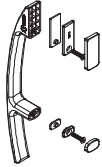
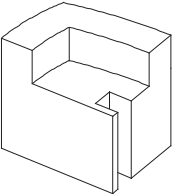
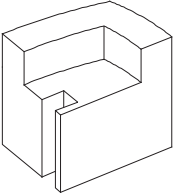
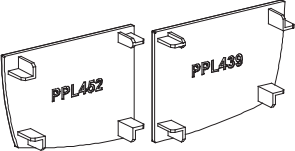
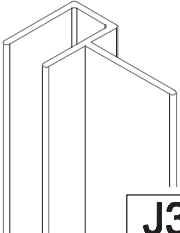
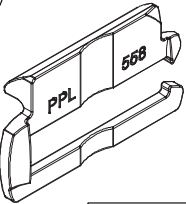
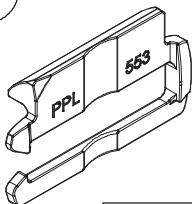

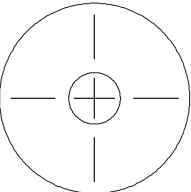

G  CHE02 x8	H  $\text{Ø } 3.9$ 45 1 = 1 VIS17 x8	
I  MOU08 x1	J  MOU03 x2	K  $\text{Ø } 3.5$ 19 1 = 1 VIS3.5x19 x14
L  BLC=ROU12 CHR=ROU19 x2	M  BLC=ROU22 CHR=ROU23 x2	N  PGN39+SET85 x1
O  MOU06 x1	P  MOU09 x1	Q  SET15 x1
R  J365 x1	S  PPL558 x1	T  PPL553 x1

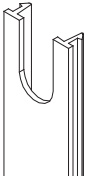
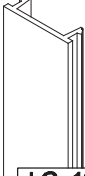
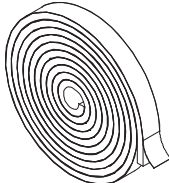
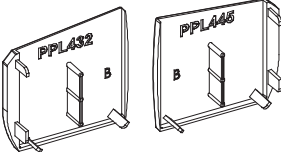
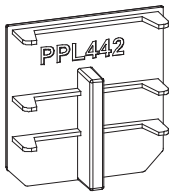
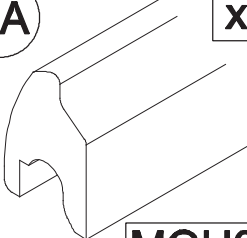
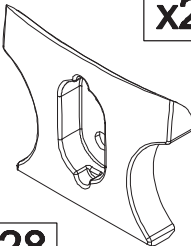
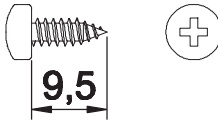
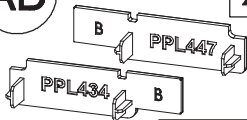
Les quantités données sont les quantités utiles au montage. Les sachets fournis contiennent des pièces supplémentaires.
 The quantities given are what are required for the installation. There may be some surplus parts in the package provided.

<p>U</p>  <p>1 = 1</p>	<p>x4</p>  <p>RON31</p>	<p>V</p>  <p>x1</p> <p>P006</p> <p>LG=1832mm</p>	<p>W</p>  <p>x2</p> <p>LG=1905mm BLC=P001 CHR=P003</p>
<p>X</p>  <p>x2</p> <p>JOI89</p>	<p>Y</p>  <p>x2</p> <p>SET08</p>	<p>Z</p>  <p>x2</p> <p>PPL442</p>	
<p>AA</p>  <p>x2</p> <p>MOU07</p>	<p>AB</p>  <p>x2</p> <p>BUT28</p>	<p>AC</p> <p>Ø 3.5</p>  <p>9,5</p> <p>1 = 1</p> <p>VIS01</p>	
<p>AD</p>  <p>x1</p> <p>SET10</p>	<p>AE</p>  <p>x2</p> <p>CAP16</p>	<p>Les quantités données sont les quantités utiles au montage. Les sachets fournis contiennent des pièces supplémentaires. The quantities given are what are required for the installation. There may be some surplus parts in the package provided.</p>	

MATERIEL NECESSAIRE - TOOLS REQUIRED

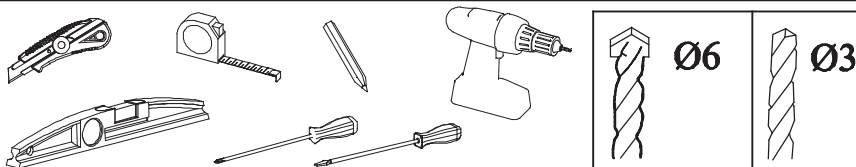

AVANT L'INSTALLATION DE VOTRE PAROI, NETTOYER LE RECEVEUR AVEC UN PRODUIT DÉGRAISSANT.

BEFORE INSTALLING YOUR SHOWER ENCLOSURE PLEASE ENSURE THAT THE TRAY SURFACES HAVE BEEN THOROUGHLY CLEANED AND ARE FREE FROM GREASE.

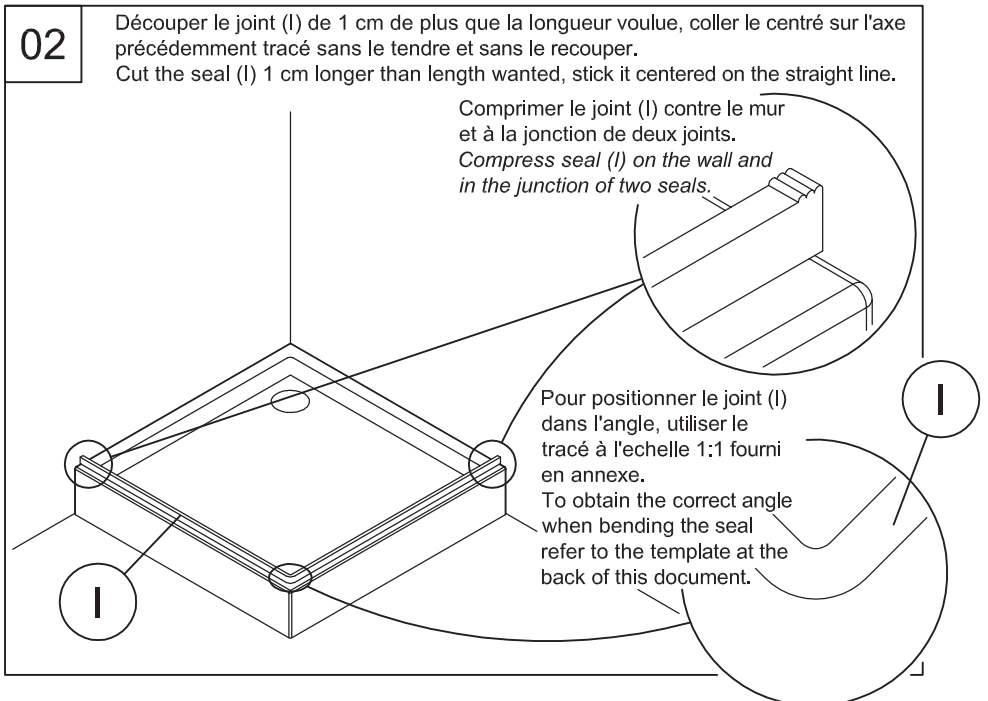
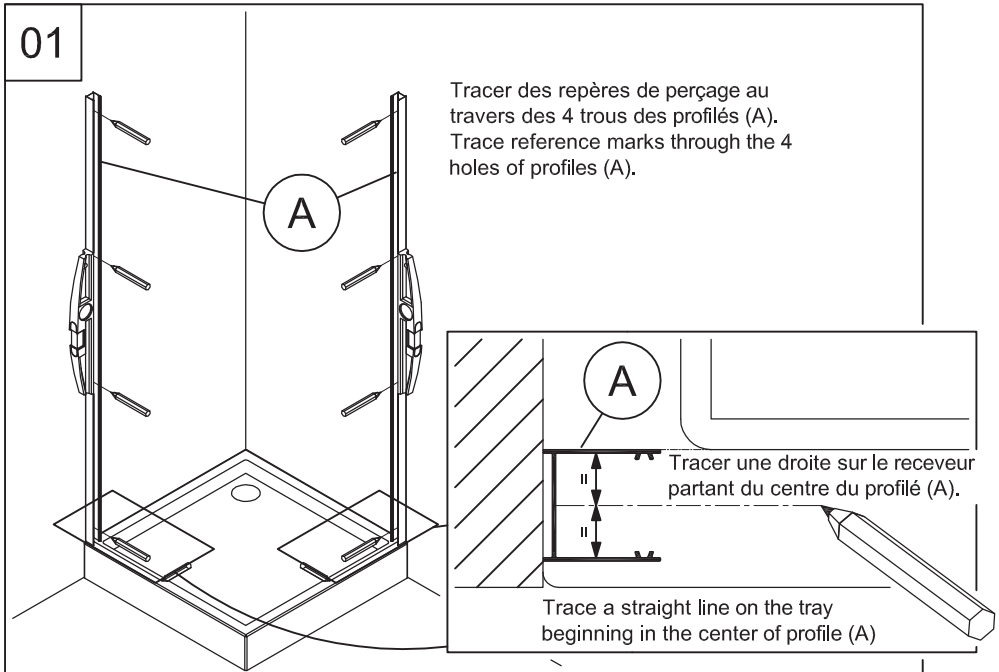

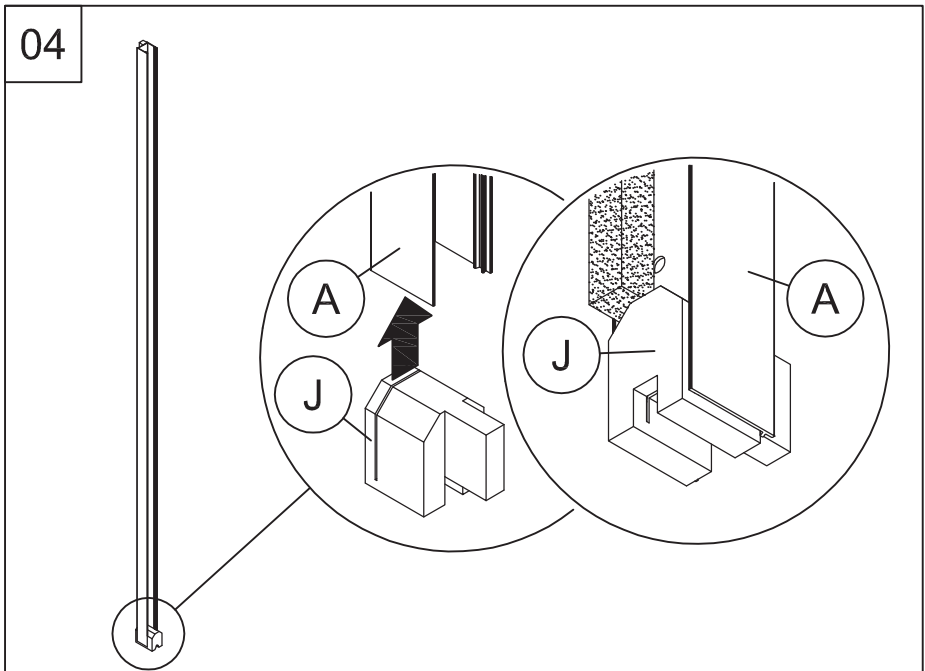
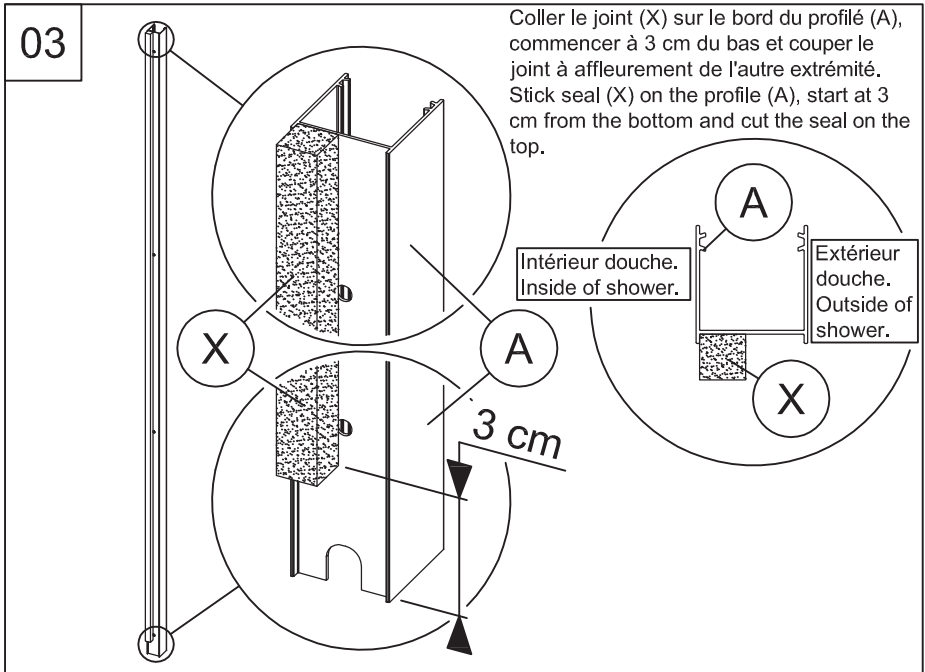

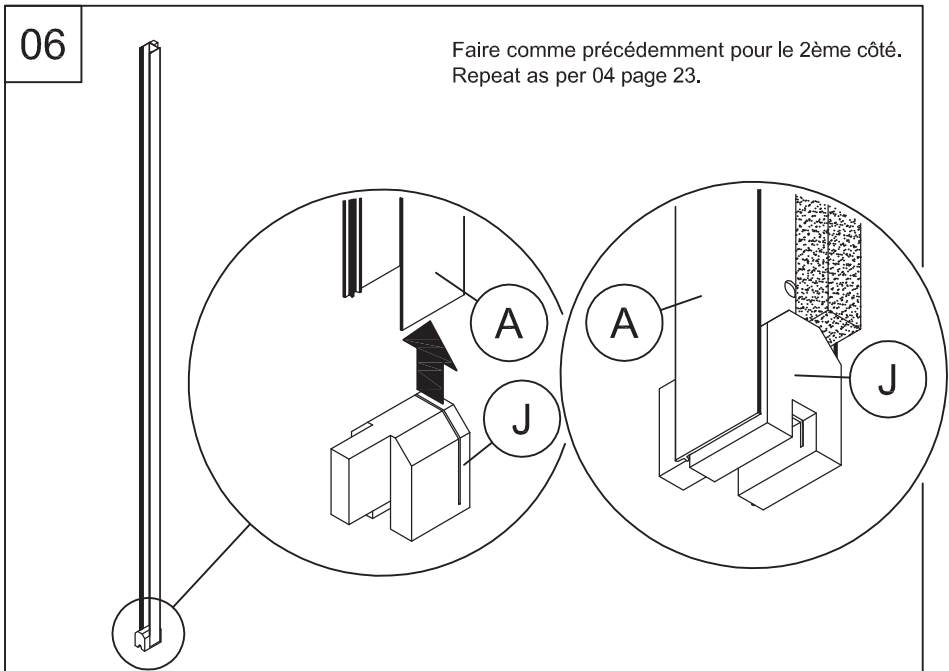
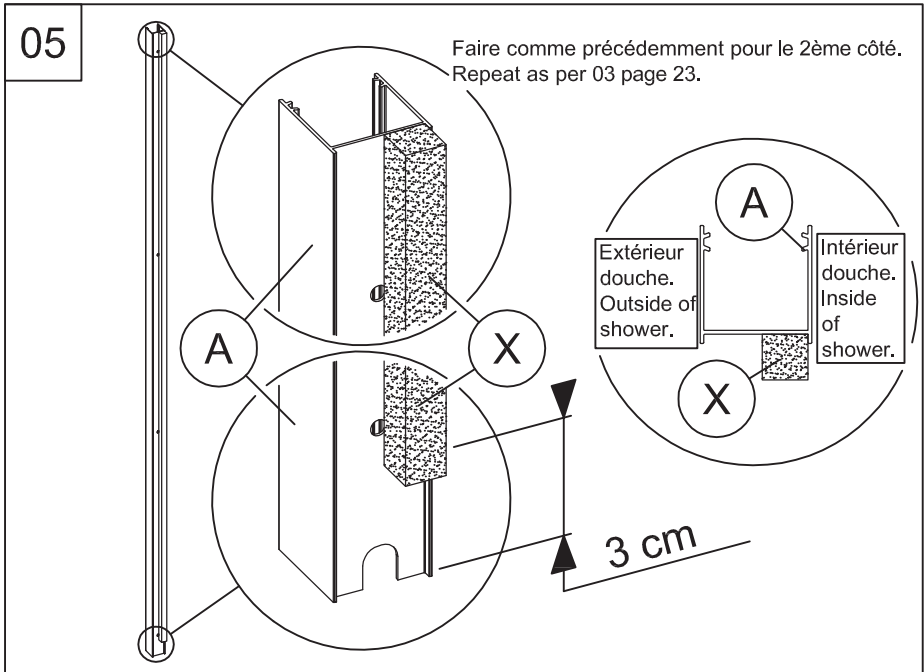

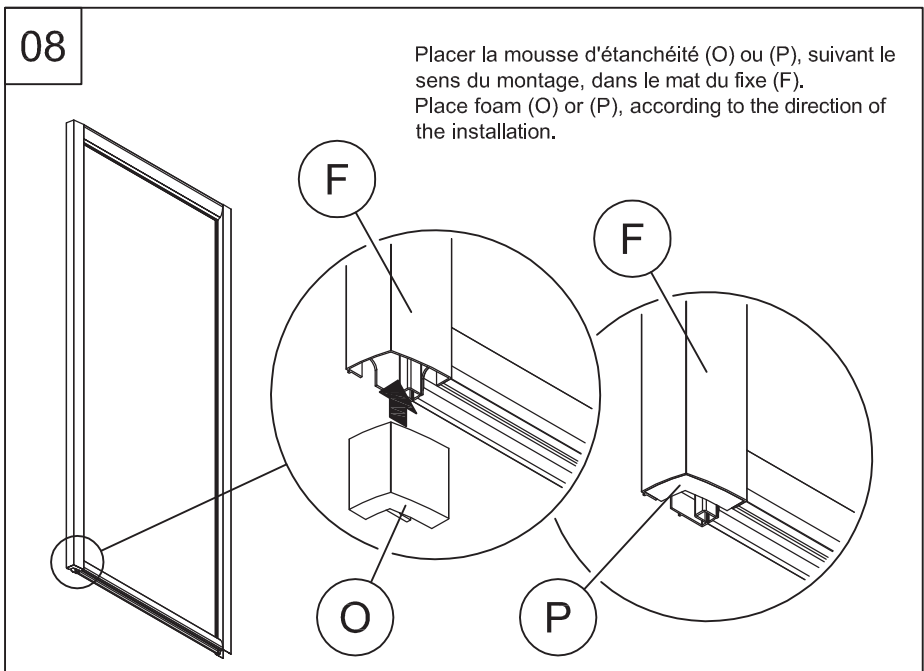
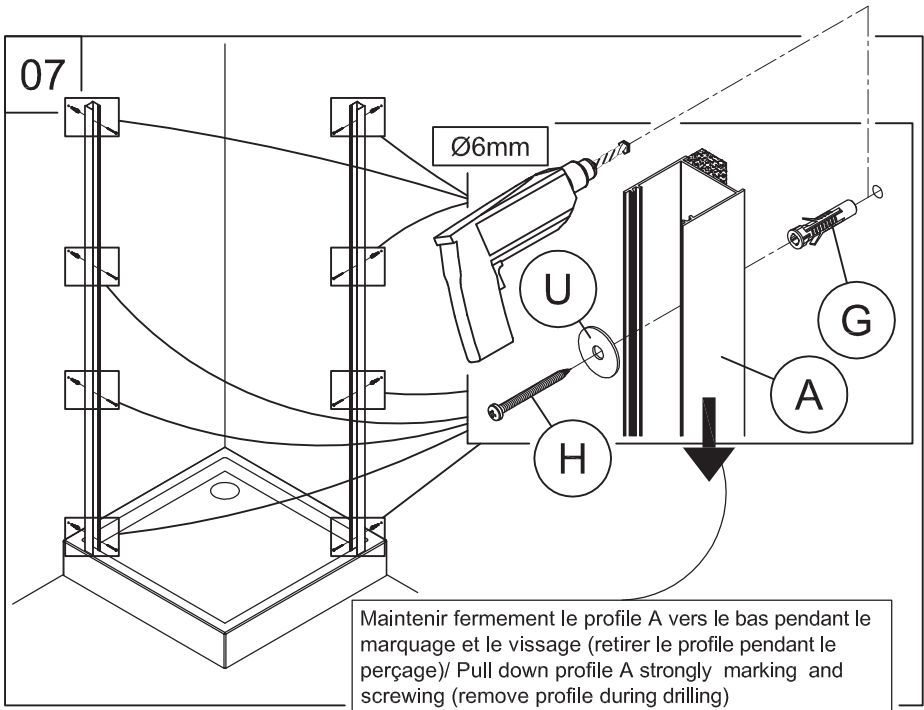

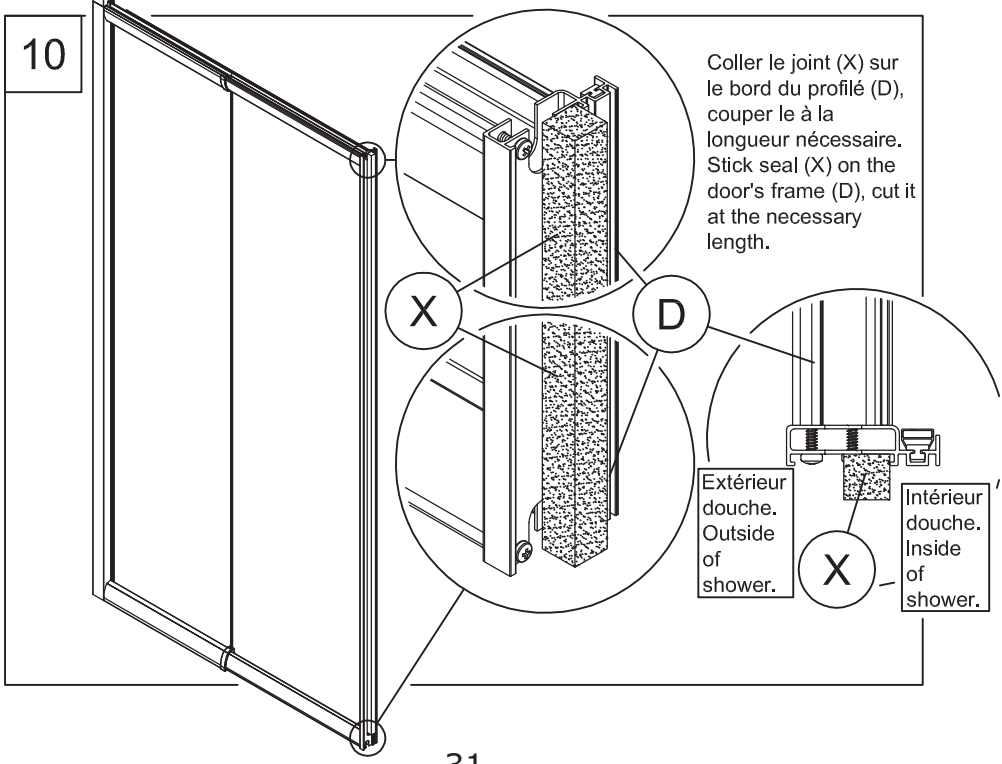
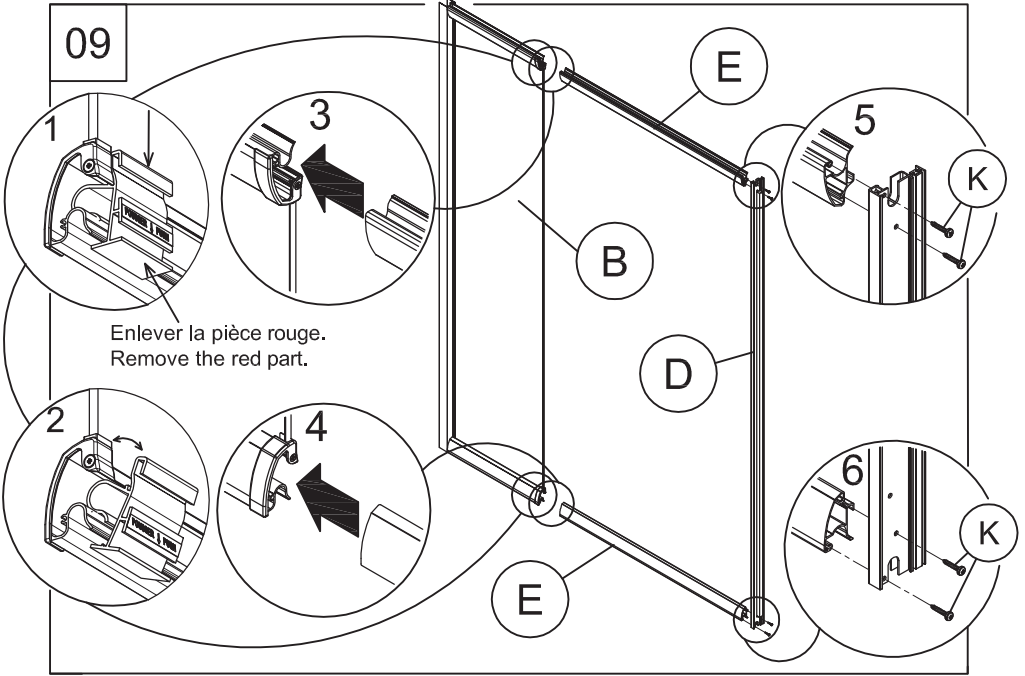

11

Emboîter la paroi (F) sur l'extérieur du profilé (A).
Slide the panel (F) over the wall profile (A).

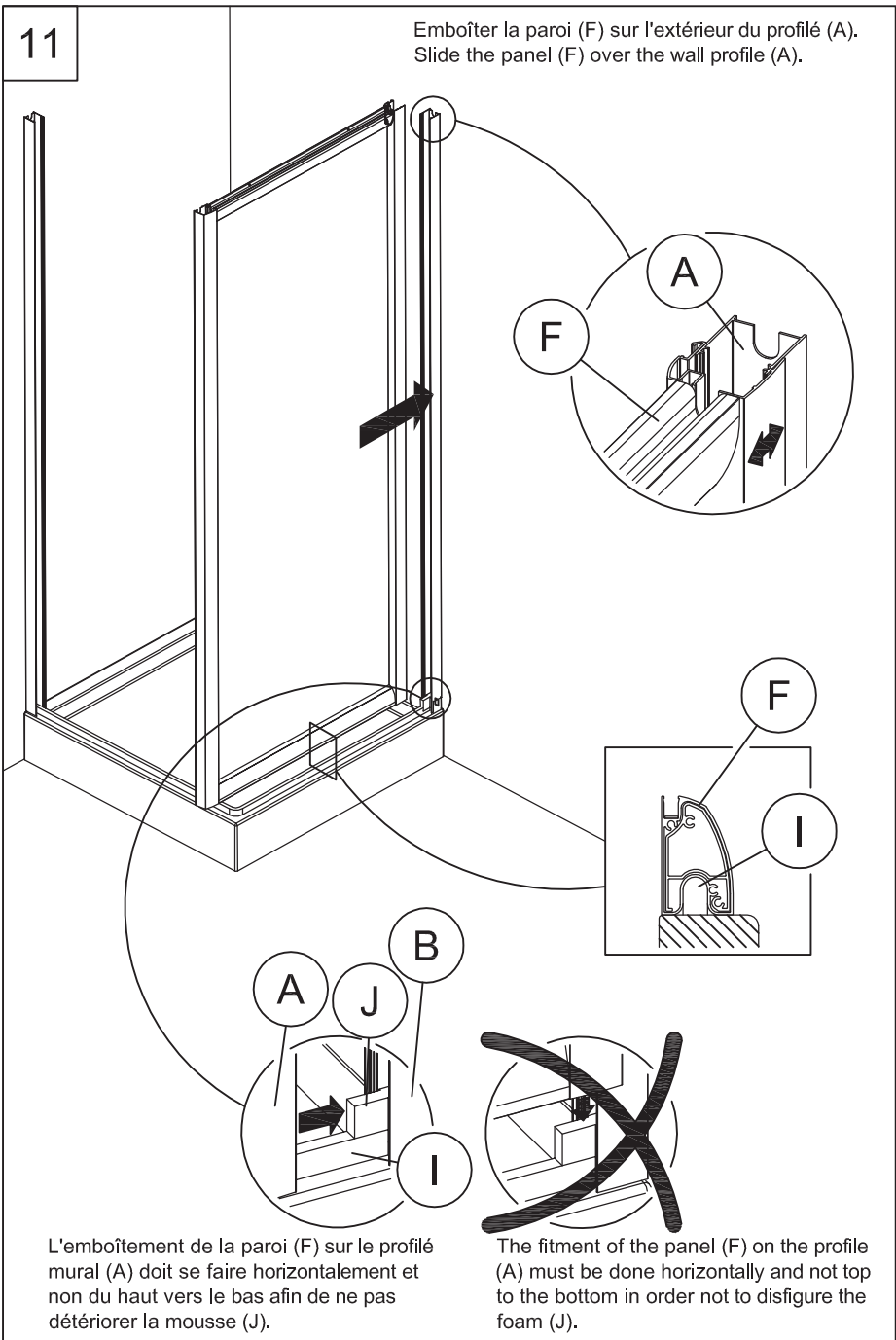

L'emboîtement de la paroi (F) sur le profilé mural (A) doit se faire horizontalement et non du haut vers le bas afin de ne pas détériorer la mousse (J).

The fitment of the panel (F) on the profile (A) must be done horizontally and not top to the bottom in order not to disfigure the foam (J).

12

Emboîter avec un légère rotation le cadre de la porte (B) sur l'extérieur du profilé (F) .
Slide the door frame (B) with little rotation over the wall profile (F).

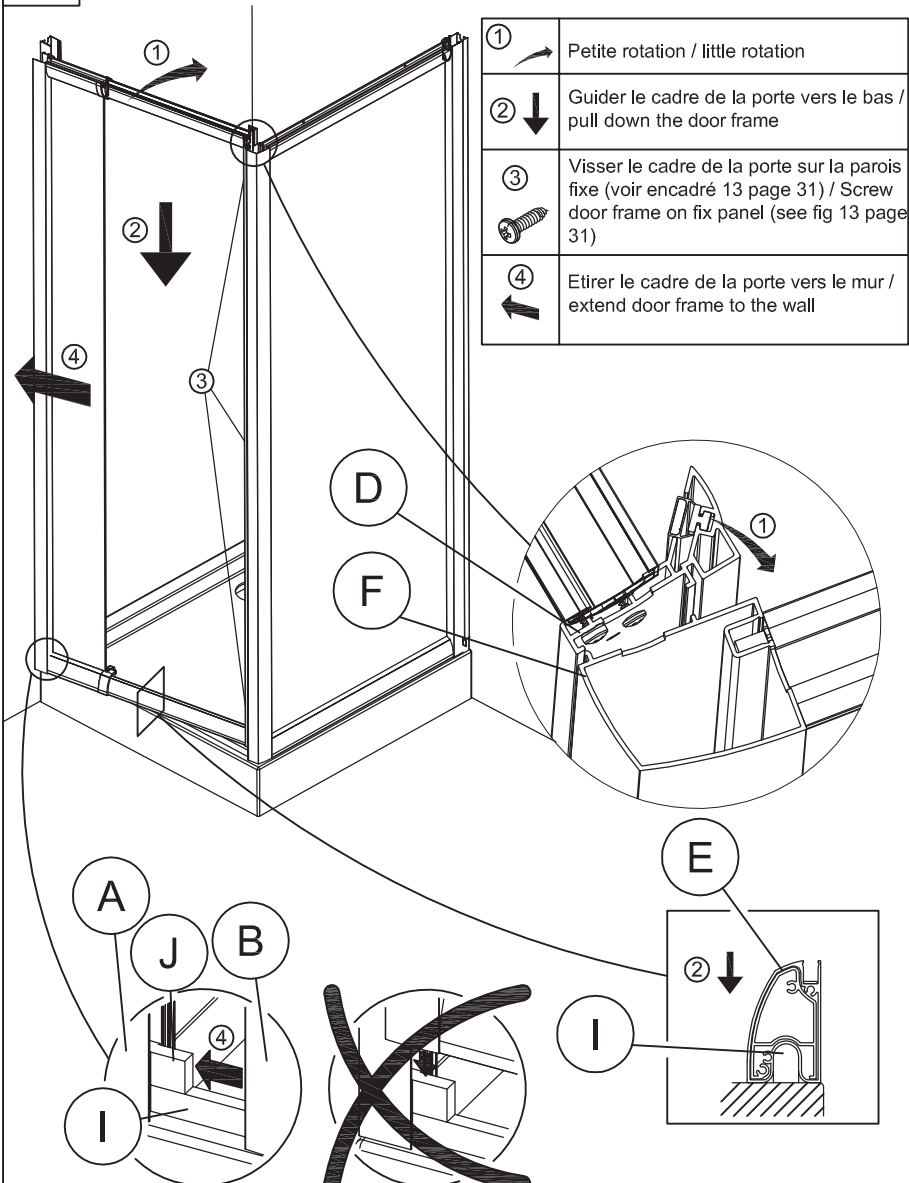

L'emboîtement du cadre de la porte (B) sur le profilé mural (A) doit se faire horizontalement et non du haut vers le bas afin de ne pas détériorer la mousse (J).

The fitment of the door's frame (B) on the profile (A) must be done horizontally and not top to the bottom in order not to disfigure the foam (J).

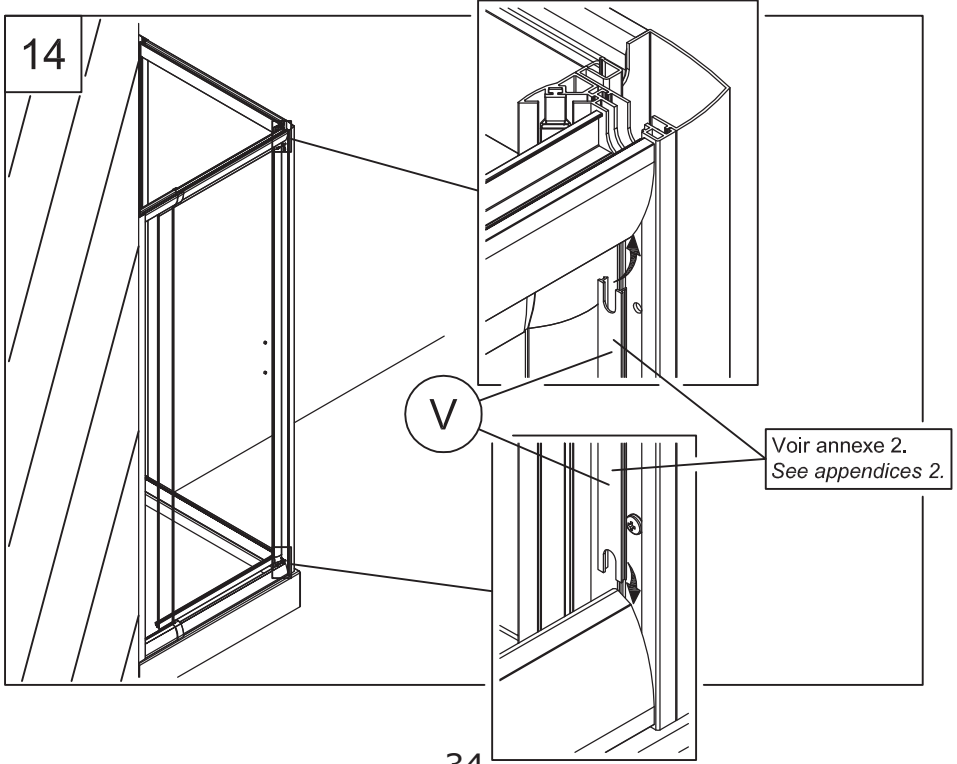
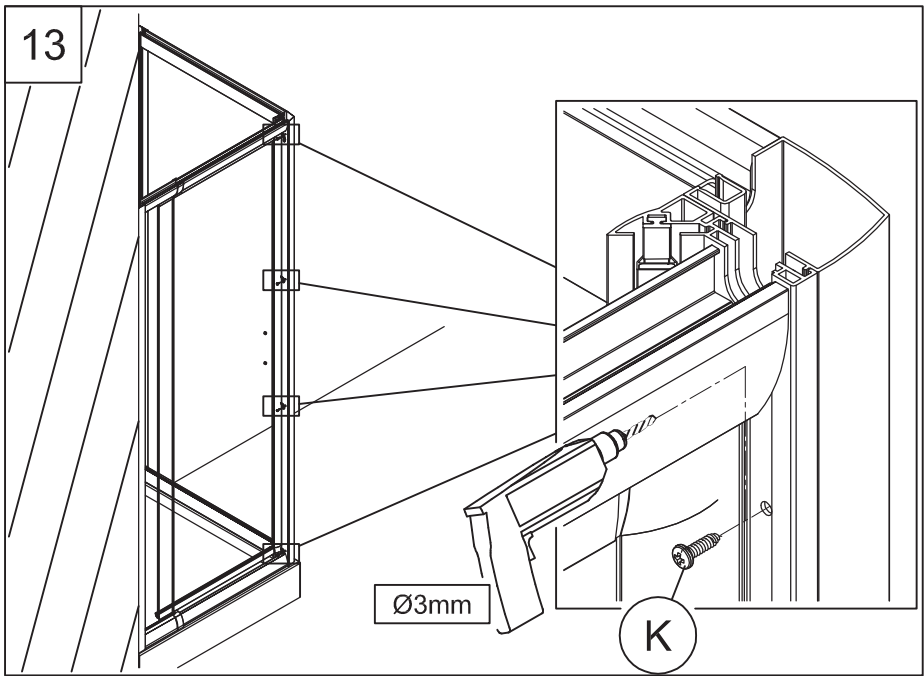

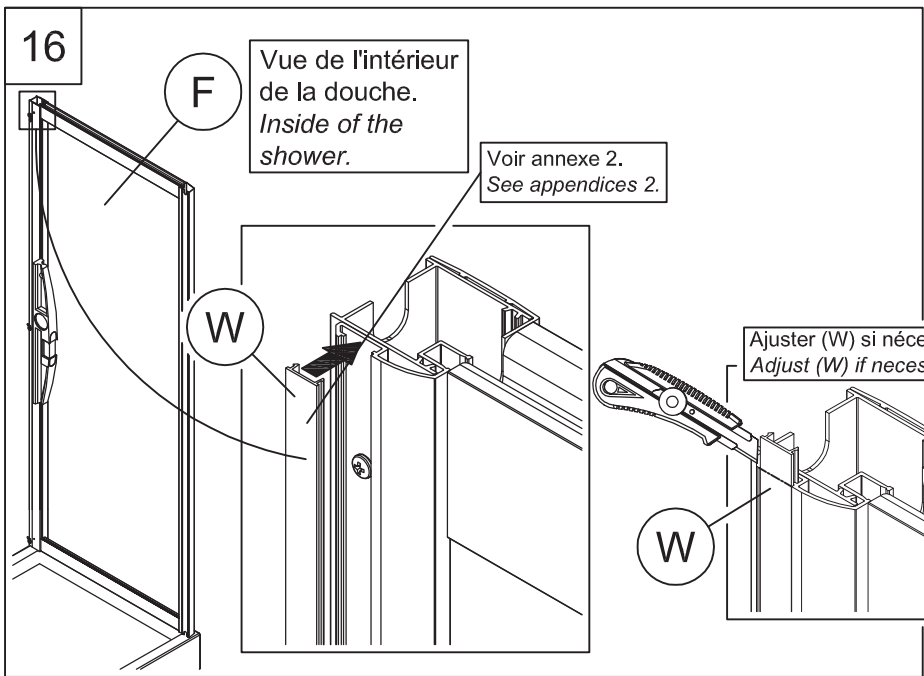
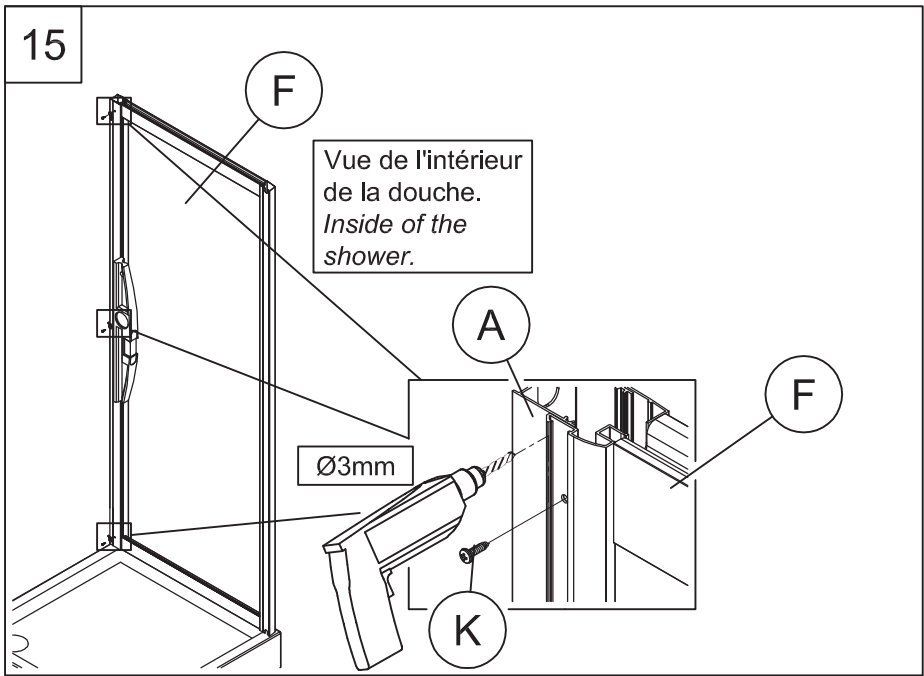

17

Vue de l'intérieur
de la douche.
Inside of the
shower.

Vérifier l'aplomb du cadre, contrepercer et fixer.
Check the frame is vertical, drill and fix.

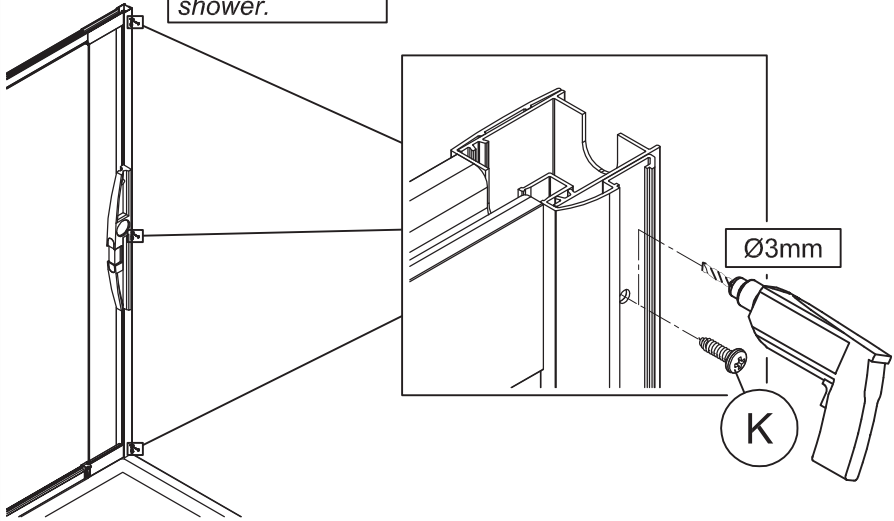

18

Ajuster (W) si nécessaire.
Adjust (W) if necessary.

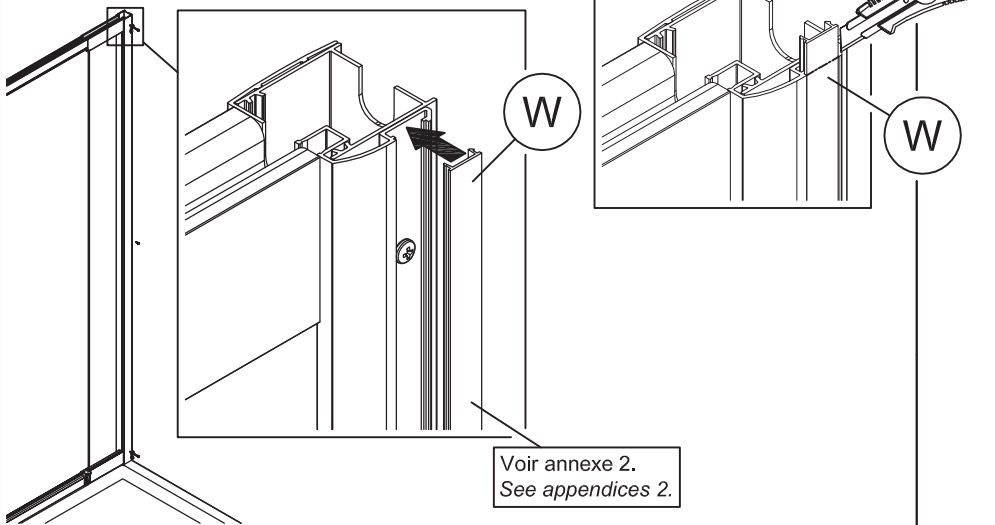

19

Positionner le joint (R) sur le verre fixe.
Attach the seal (R) to the fixed panel.

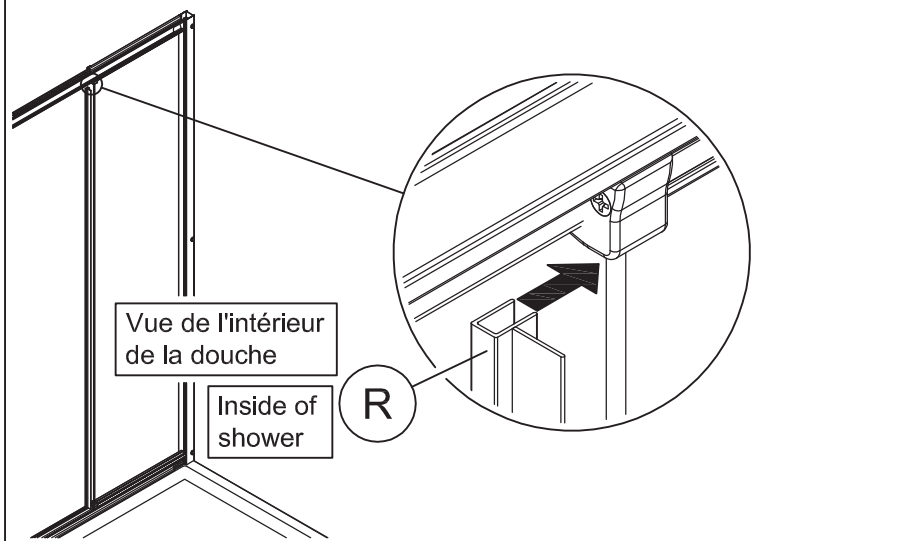

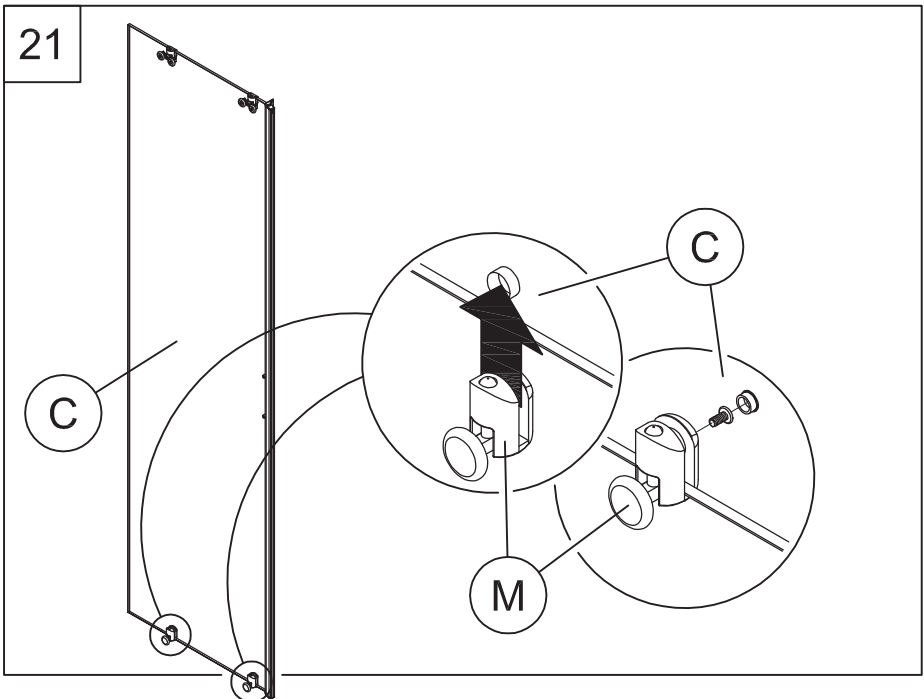
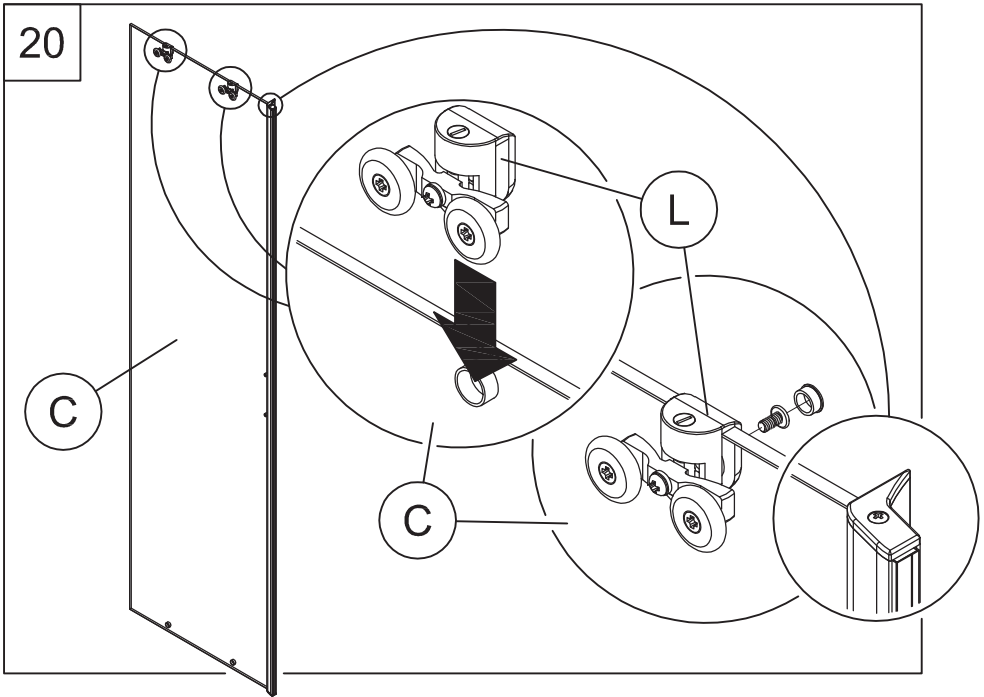

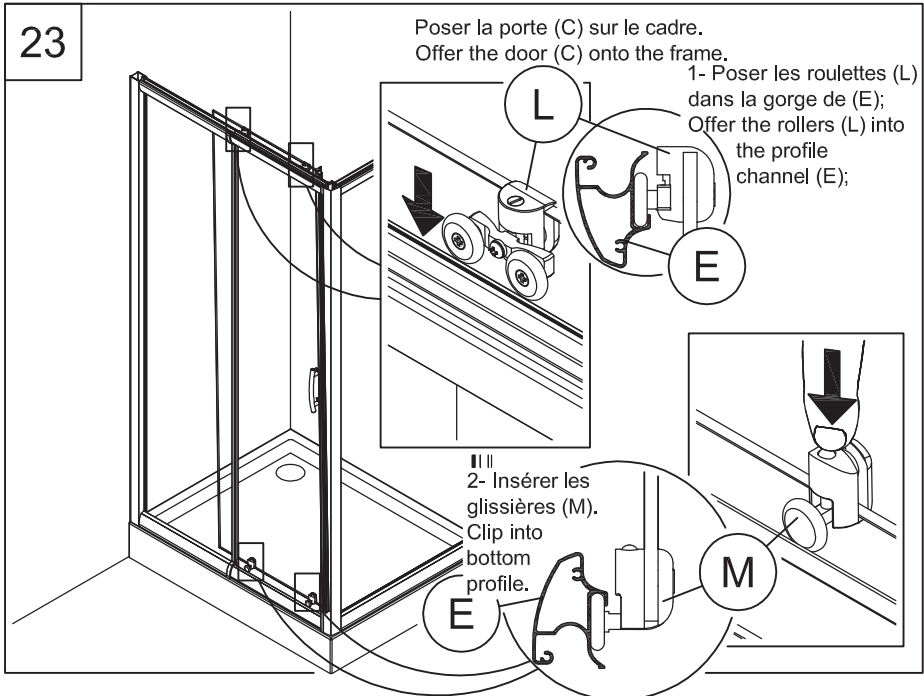
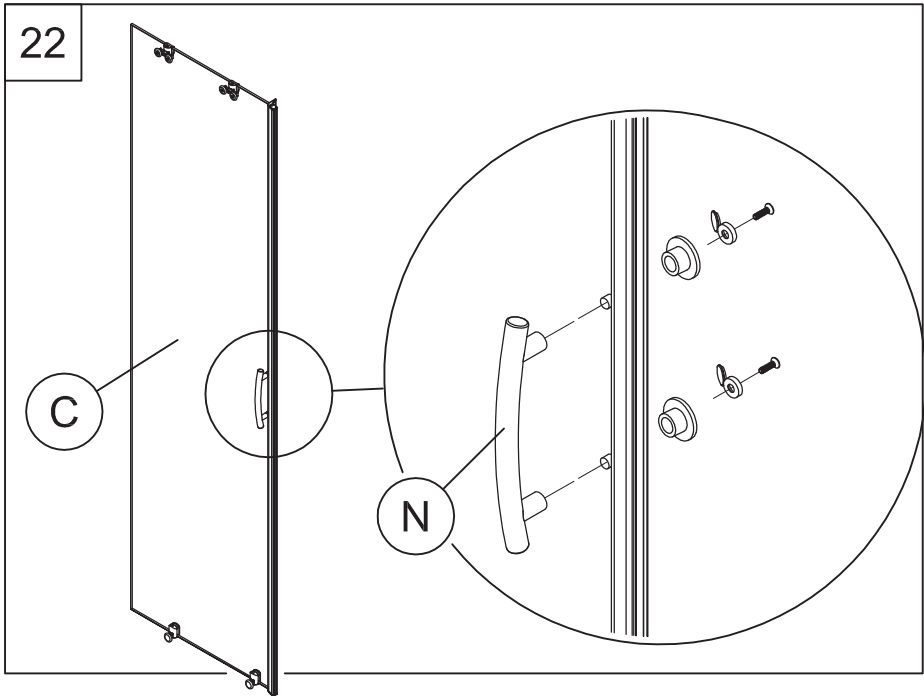

24

Réglage de la porte :
agir sur l'inclinaison de la porte en ajustant les vis des roulettes (L).
Adjust the door via the rollers (L).

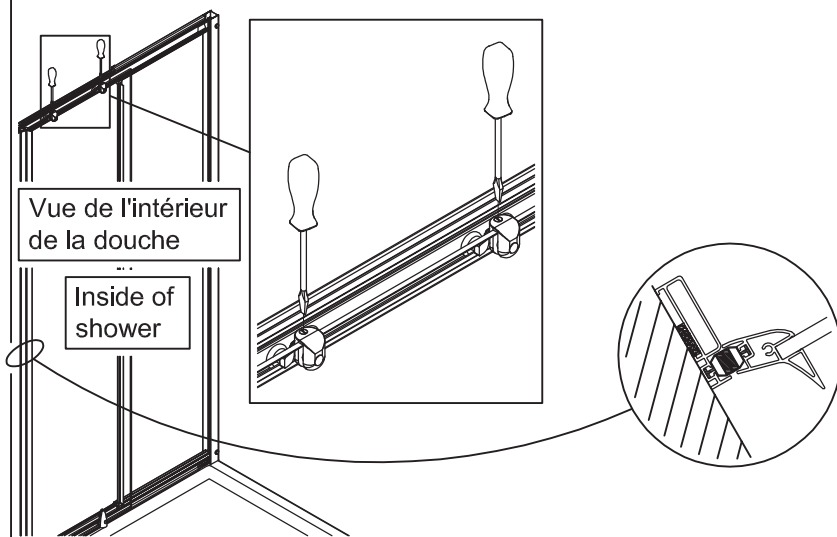

25

Ouvrir la porte de façon à avoir la poignée à 2,5 cm du verre fixe.
Open the door so that the door handle is 2.5cm from the fixed panel.

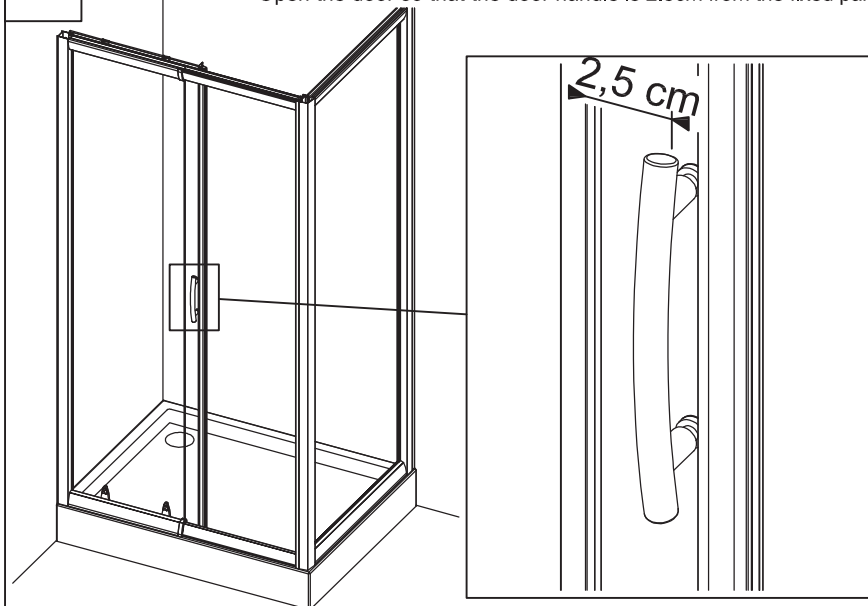

26

Fixer les butées (AB) afin :
 - de bloquer l'ouverture de la porte dans la position
 précédemment réglée,
 - et de bloquer les extensions (E).
 Fix the door stops so that it opens correctly.

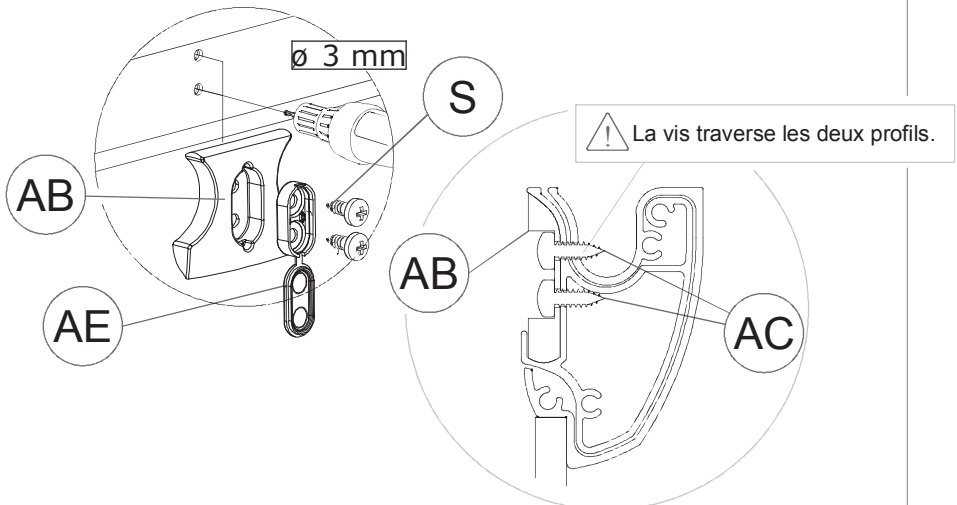
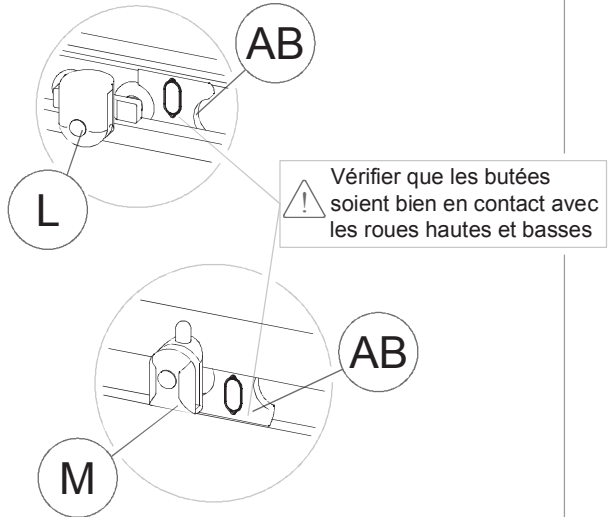
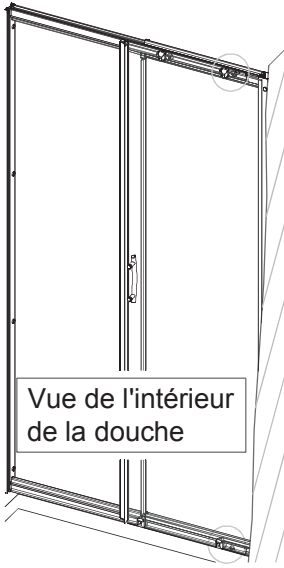

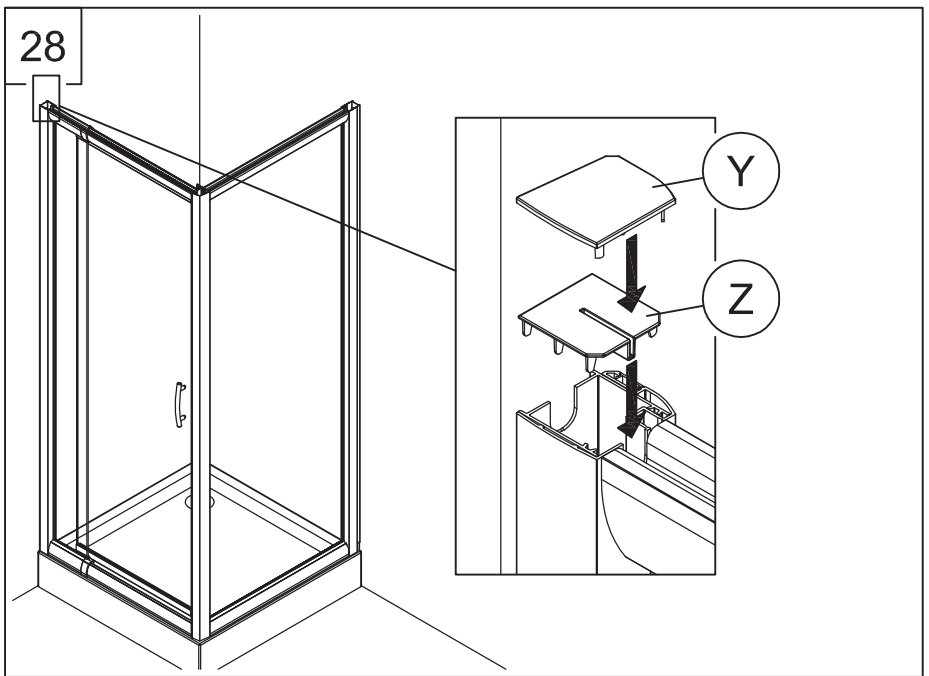
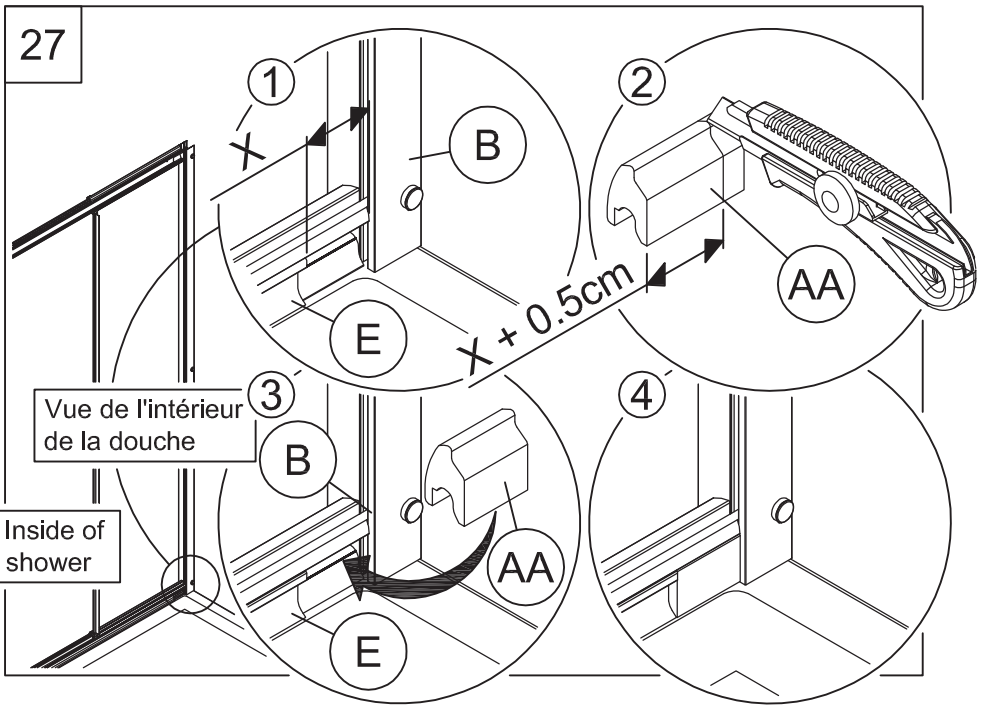

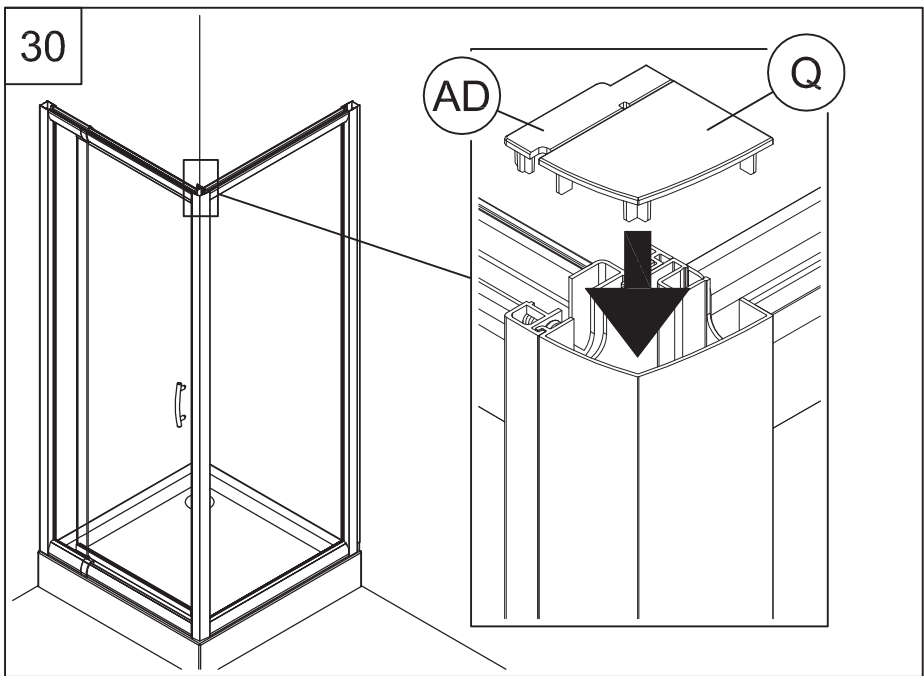
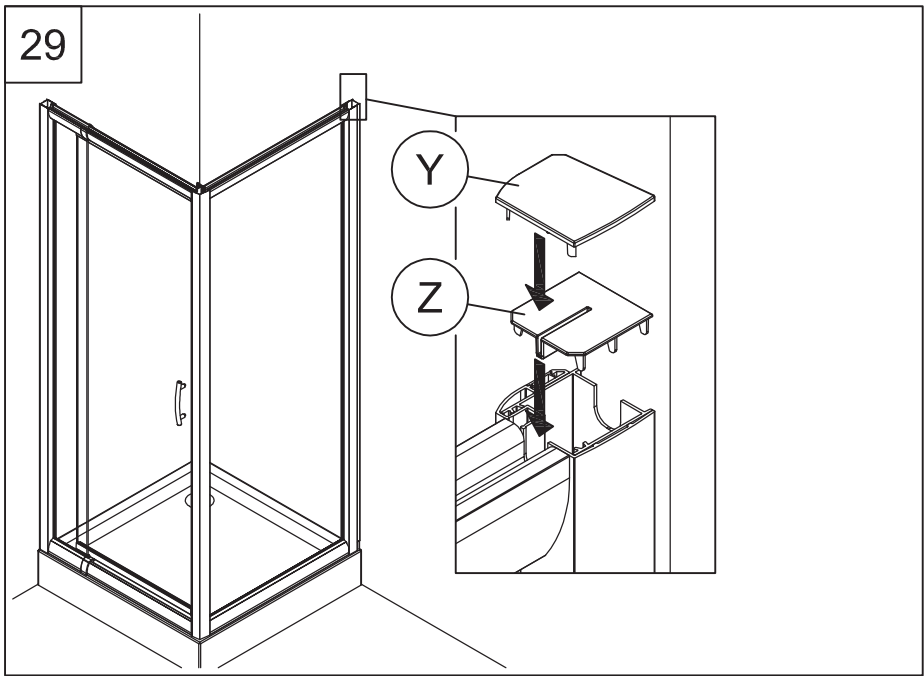

31

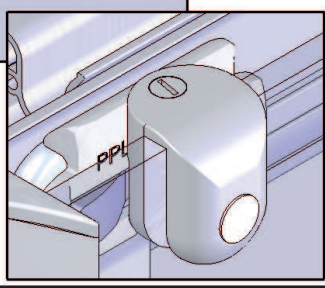
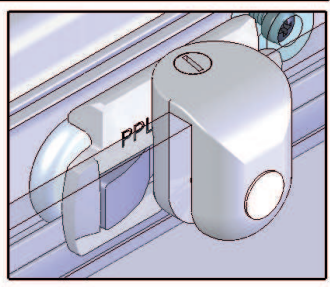
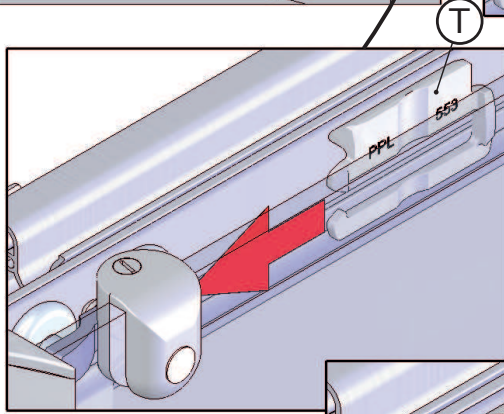
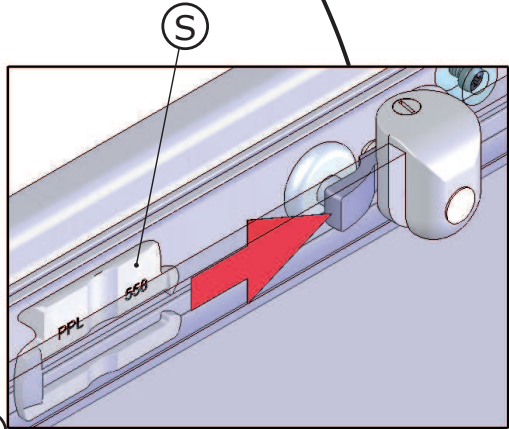
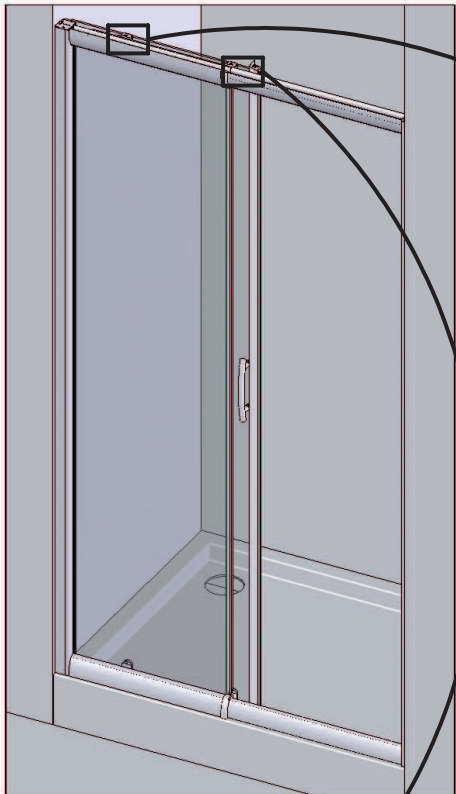

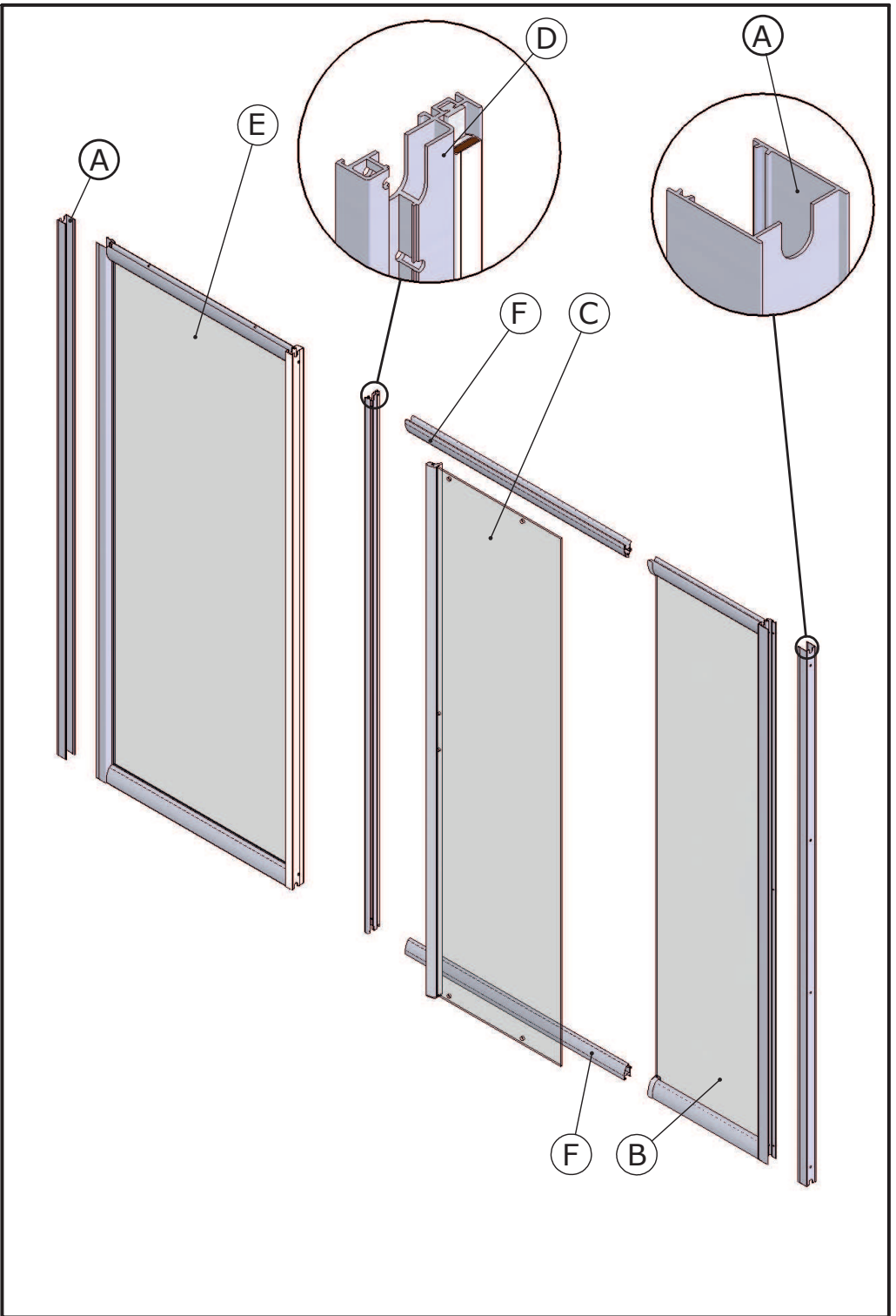

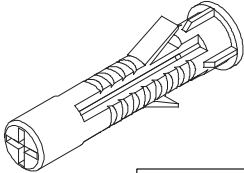
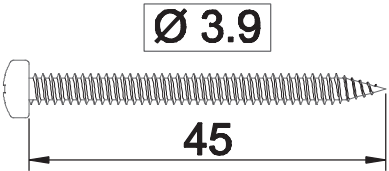
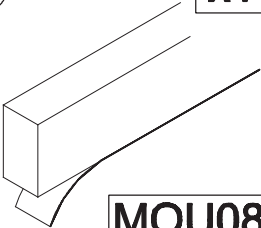
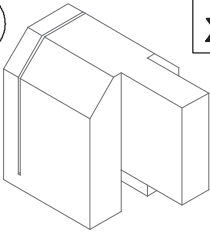
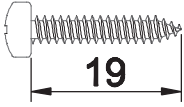
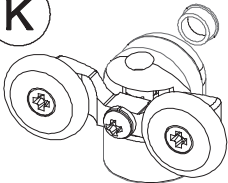
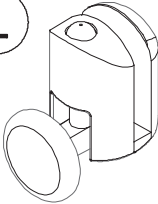
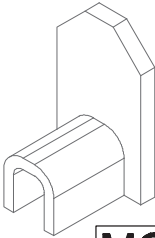
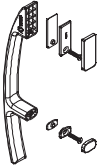
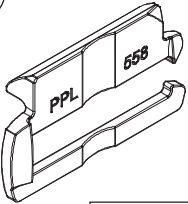
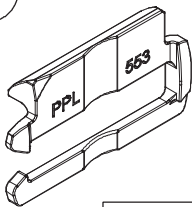
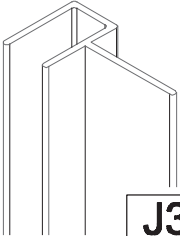
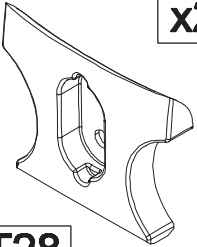
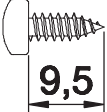
F  CHE02 x8	G  $\text{Ø } 3.9$ 45 1 = 1 VIS17 x8	
H  MOU08 x1	I  MOU03 x2	J  $\text{Ø } 3.5$ 19 1 = 1 VIS3.5x19 x14
K  BLC=ROU12 CHR=ROU19 x2	L  BLC=ROU22 CHR=ROU23 x2	M  MOU04 x1
N  PGN39+SET85 x1	O  PPL558 x1	P  PPL553 x1
Q  J365 x1	R  BUT28 x2	S  $\text{Ø } 3.5$ 9,5 1 = 1 VIS01 x4

Les quantités données sont les quantités utiles au montage. Les sachets fournis contiennent des pièces supplémentaires.
 The quantities given are what are required for the installation. There may be some surplus parts in the package provided.

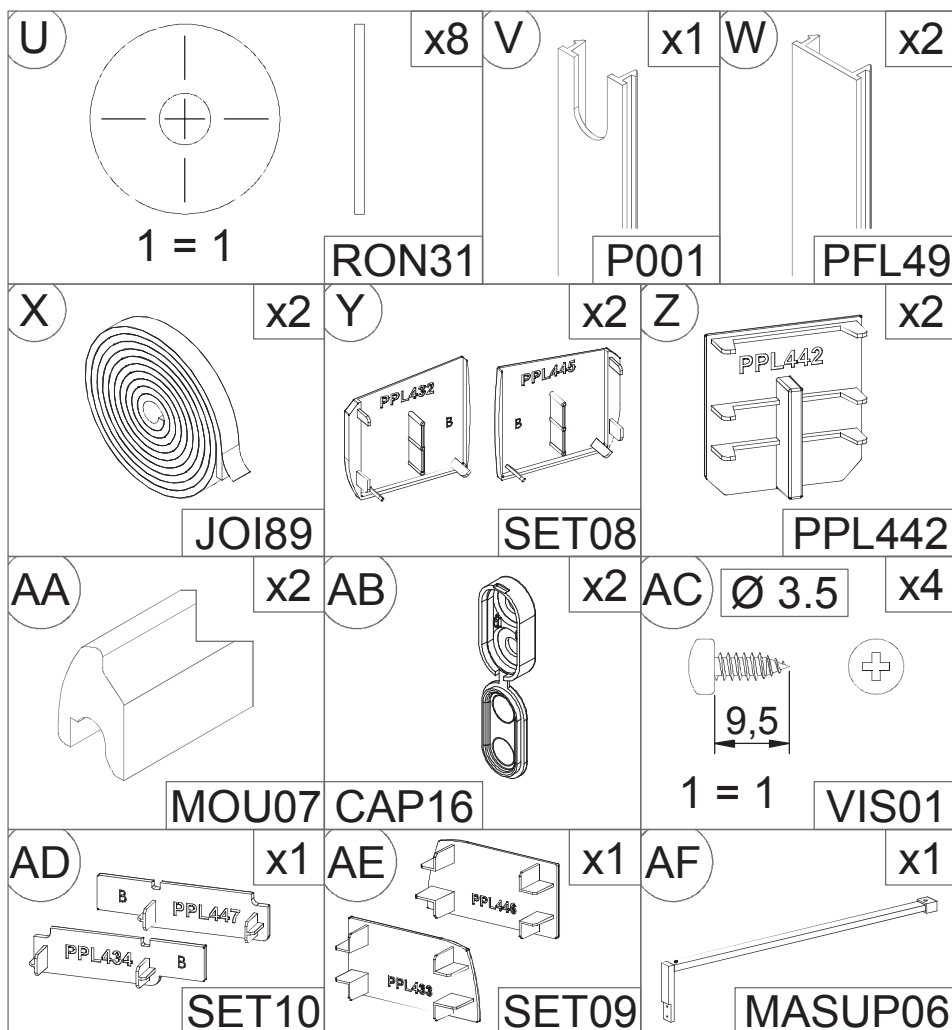

Les quantités données sont les quantités utiles au montage. Les sachets fournis contiennent des pièces supplémentaires.
 The quantities given are what are required for the installation. There may be some surplus parts in the package provided.

MATERIEL NECESSAIRE - TOOLS REQUIRED

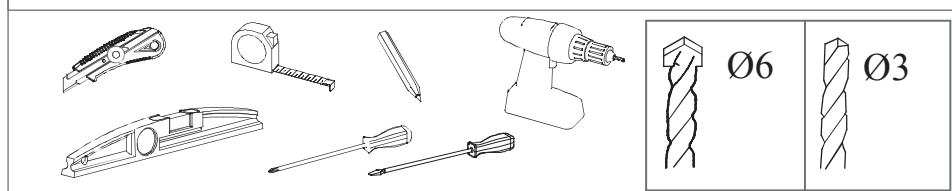

AVANT L'INSTALLATION DE VOTRE PAROI, NETTOYER LE RECEVEUR AVEC UN PRODUIT DÉGRAISSANT.

BEFORE INSTALLING YOUR SHOWER ENCLOSURE PLEASE ENSURE THAT THE TRAY SURFACES HAVE BEEN THOROUGHLY CLEANED AND ARE FREE FROM GREASE.

01

Tracer des repères de perçage au travers des 4 trous du profilé (A).

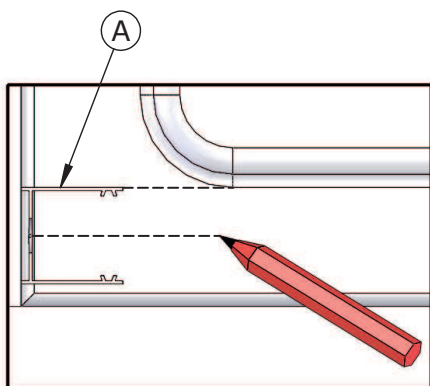
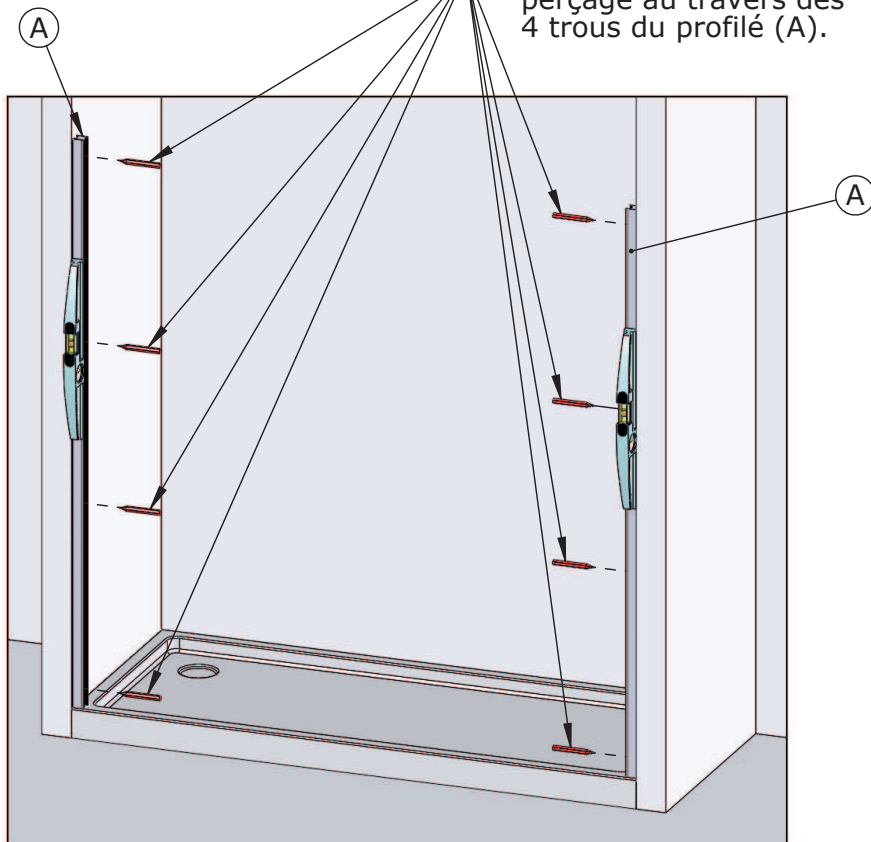

Tracer une droite sur le receveur partant du centre du profilé (A).

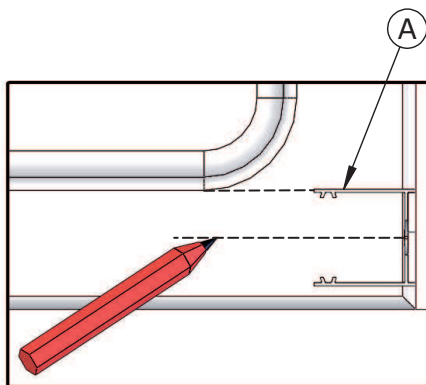

Tracer une droite sur le receveur partant du centre du profilé (A).

- ② 1- Découper le joint (H) à la longueur (L) + 1 cm
2 - Coller le joint (H) centré sur l'axe précédemment tracé sans le tendre.

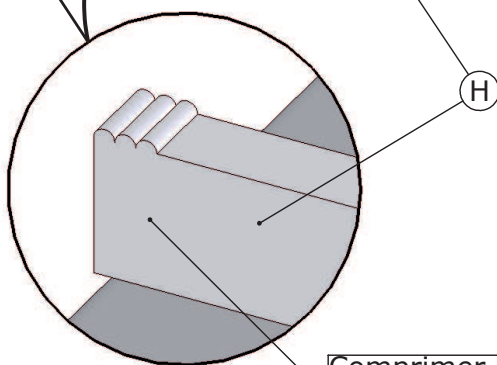
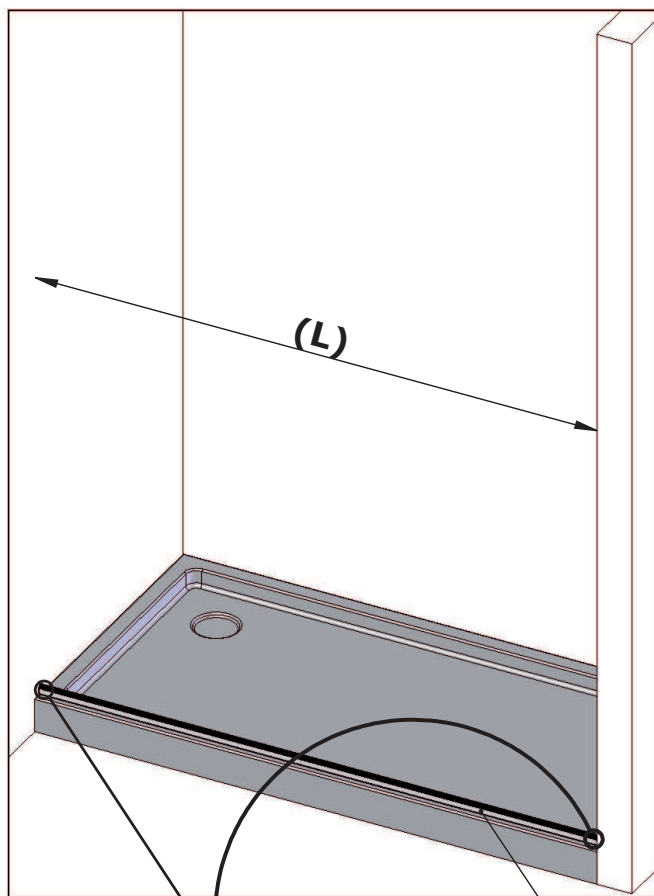

Comprimer le joint (H) contre le mur et à la jonction de deux joints.

- 03 Coller le joint (X) sur le bord du profilé (A), commencer à 3 cm du bas et couper le joint à affleurement de l'autre extrémité.

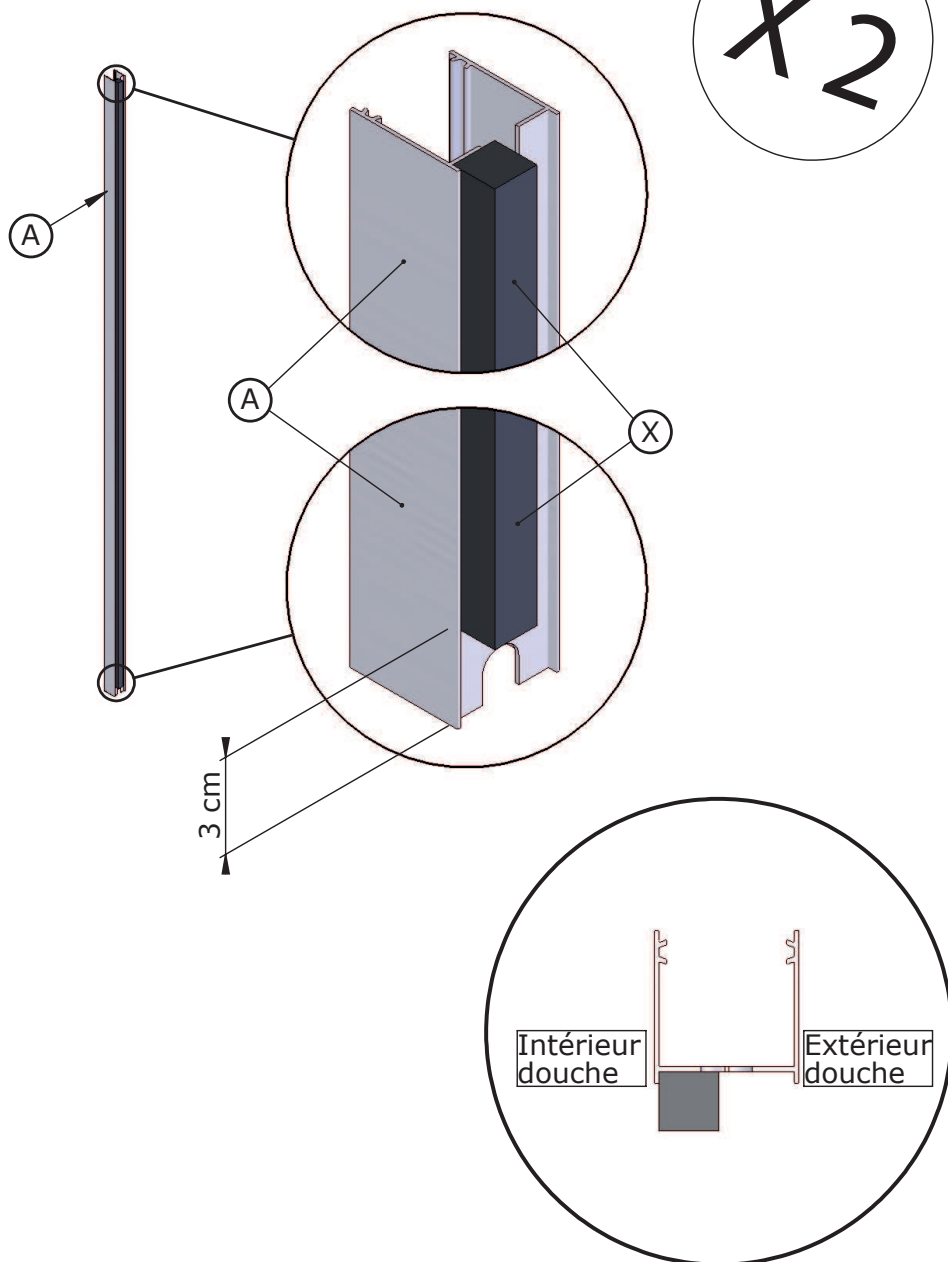

04

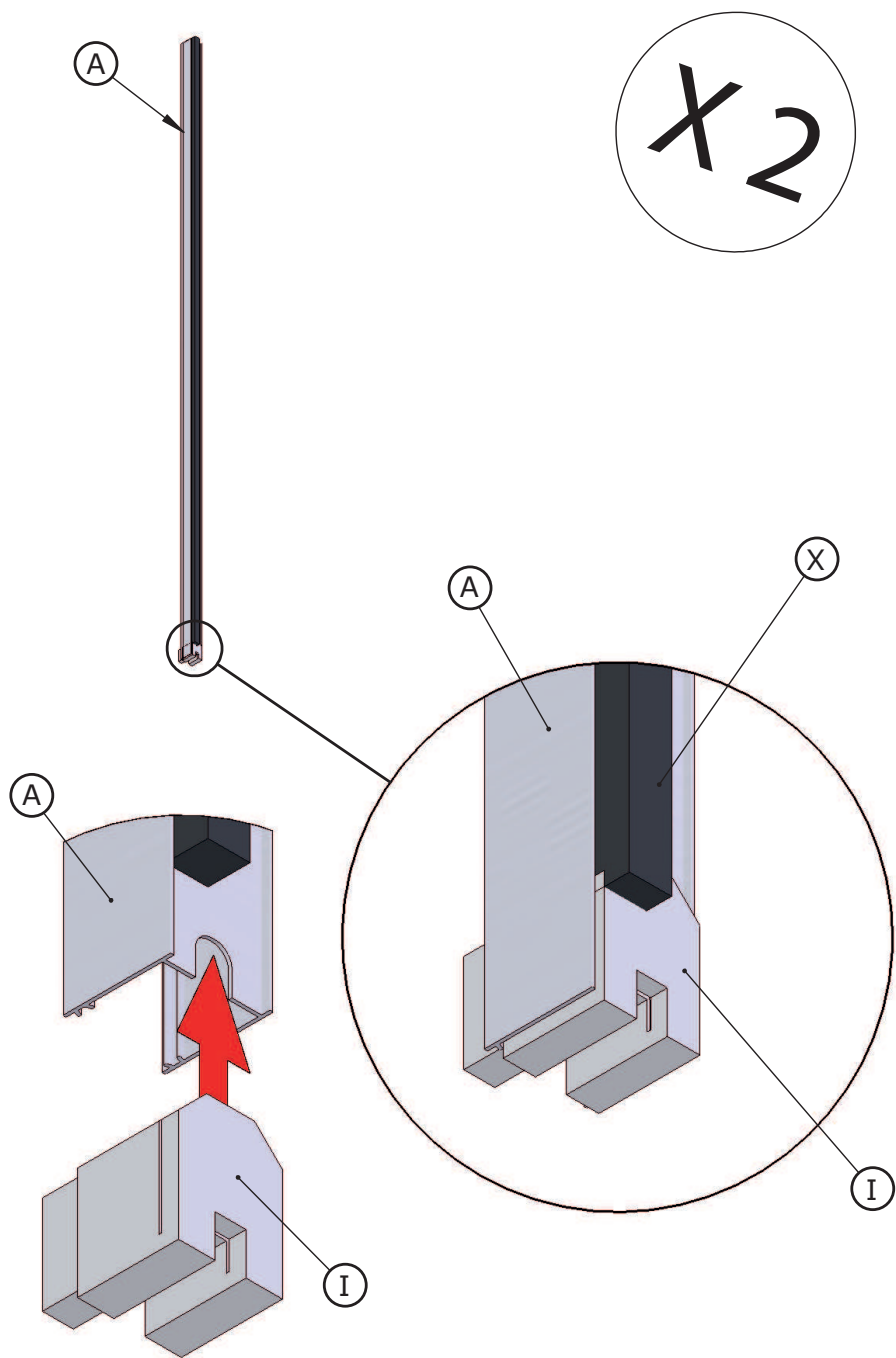

05

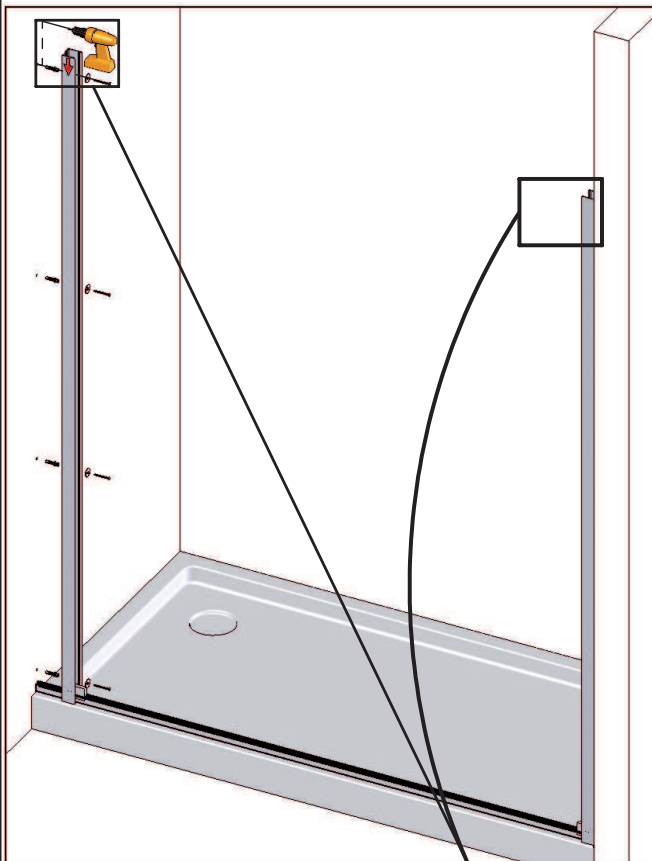

Ø6 mm

Maintenir fermement le profile (A) vers le bas pendant le marquage et le vissage (retirer le profile pendant le perçage)

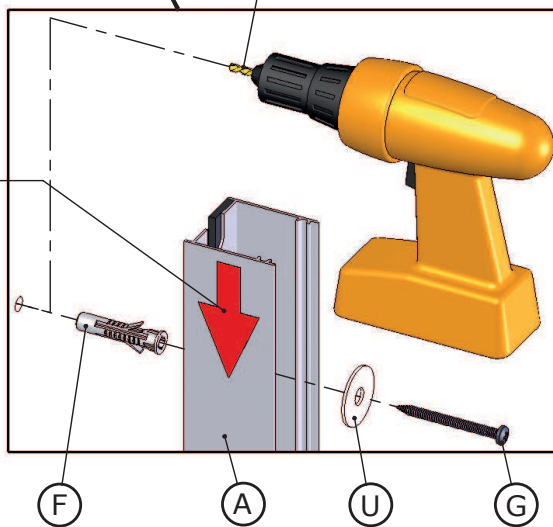

F

A

U

G

①⑥ Emboîter la paroi (E) sur l'extérieur du profilé (A).

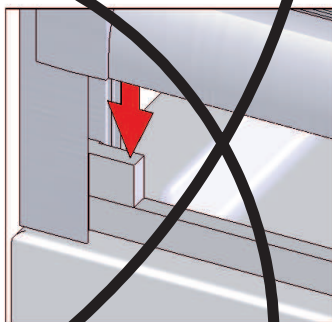
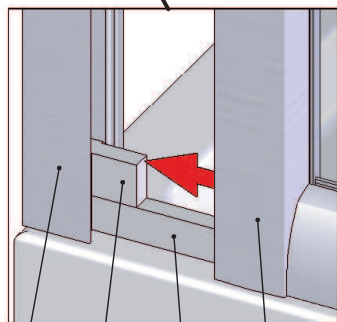
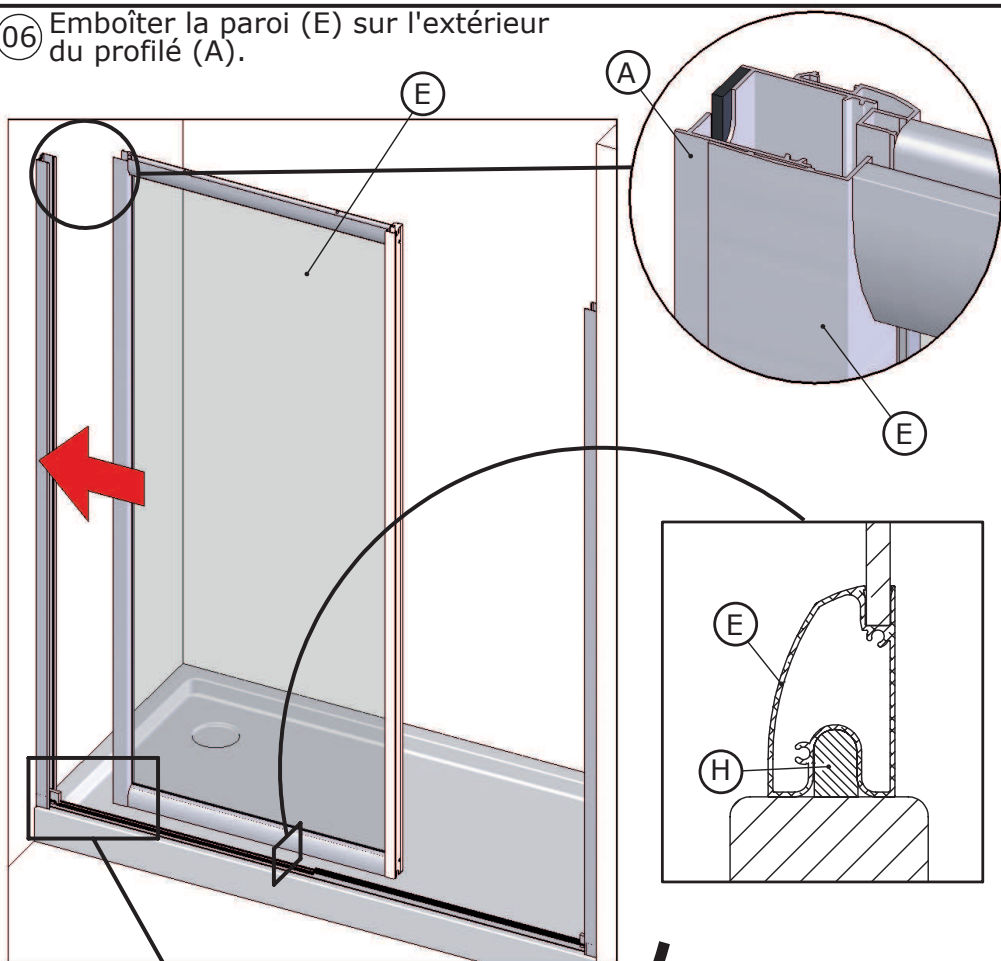

① A ① I ① H ① E

L'emboîtement de la paroi (E) sur le profilé mural (A) doit se faire horizontalement et non du haut vers le bas afin de ne pas détériorer la mousse (I).

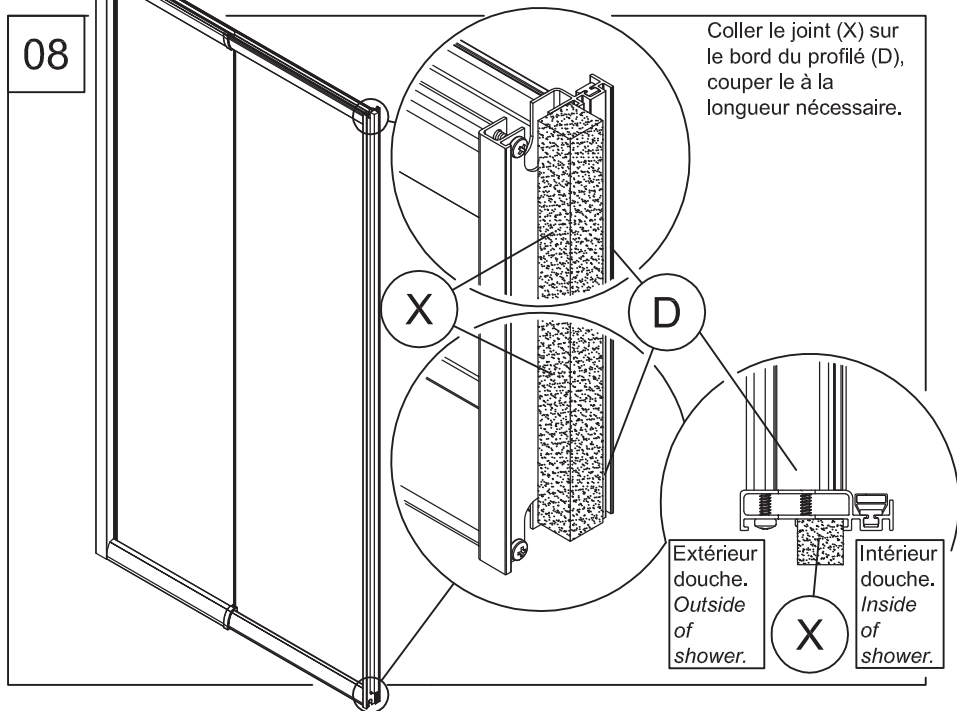
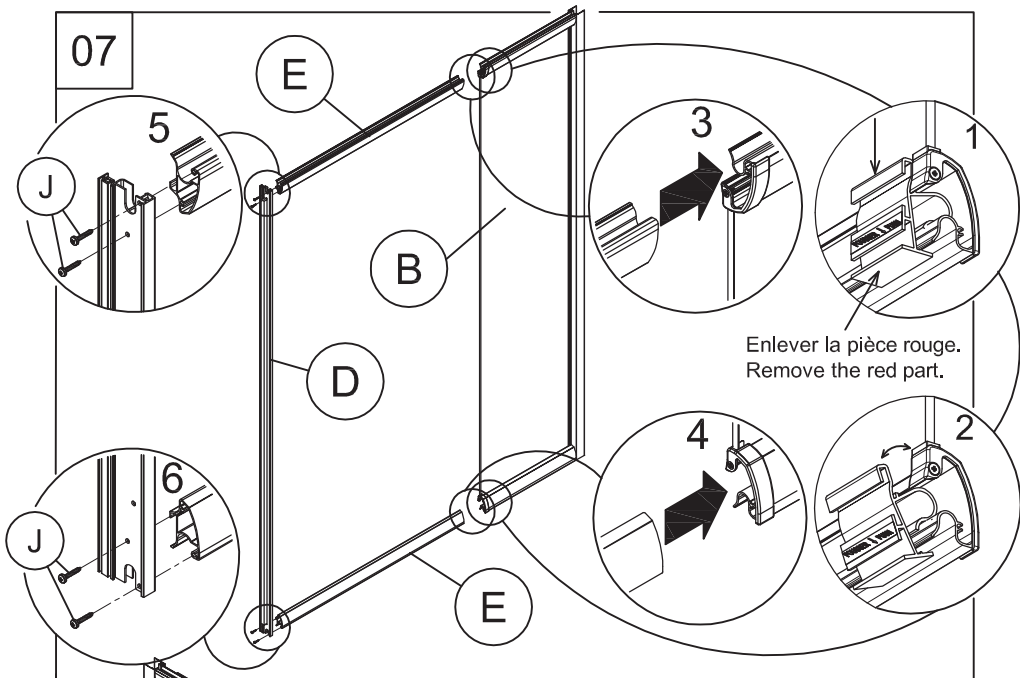

- 09 Emboîter le cadre de la porte (B) sur l'extérieur du profilé (A).

- ① Petite rotation
- ② Guider le cadre de la porte vers le bas
- ③ Visser le cadre de la porte sur la paroi fixe (encadré 10)
- ④ Etirer le cadre de la porte vers la mur

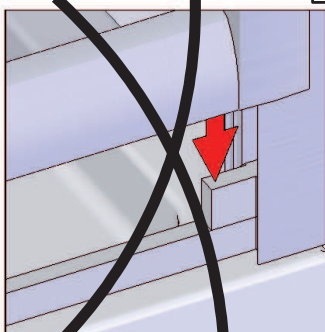
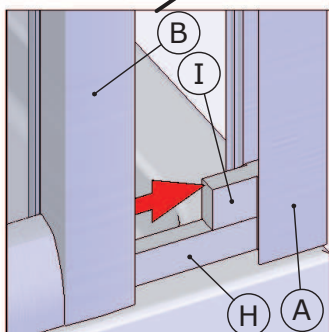
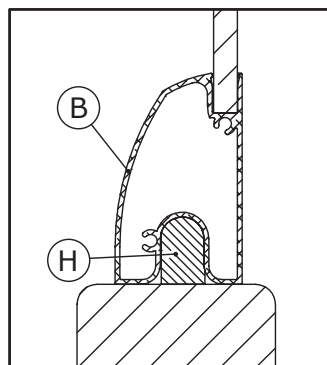
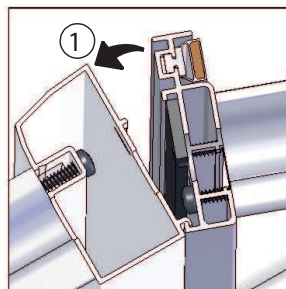
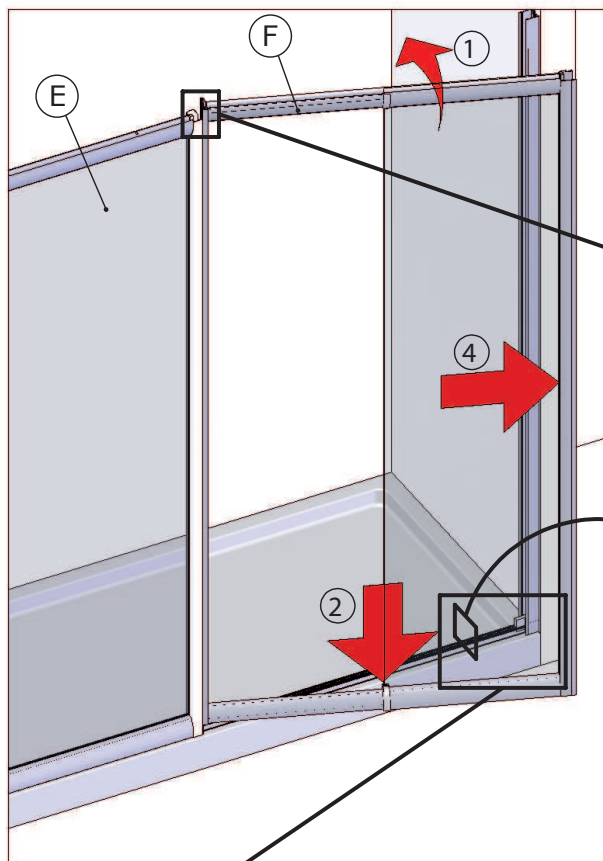

L'emboîtement du cadre de la porte (B) sur le profilé mural (A) doit se faire horizontalement et non du haut vers le bas afin de ne pas détériorer la mousse (I).

10

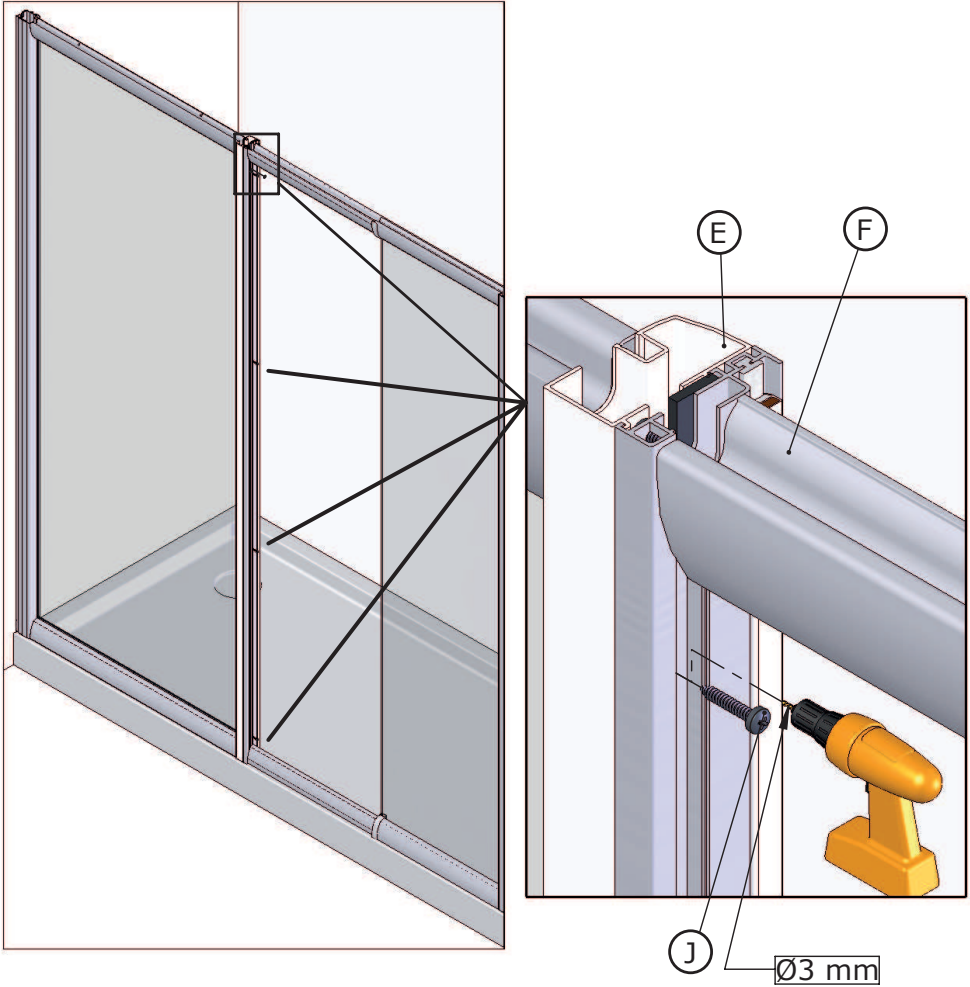

11

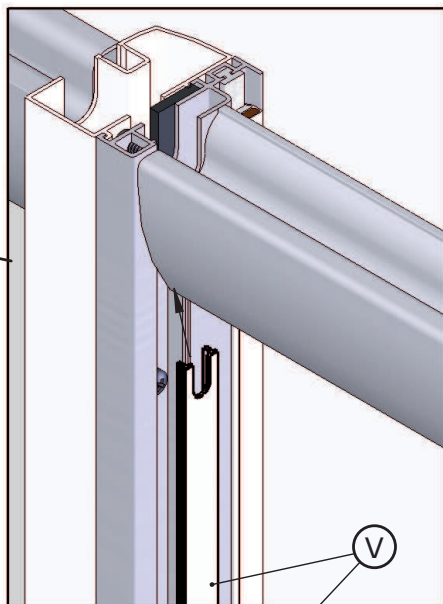
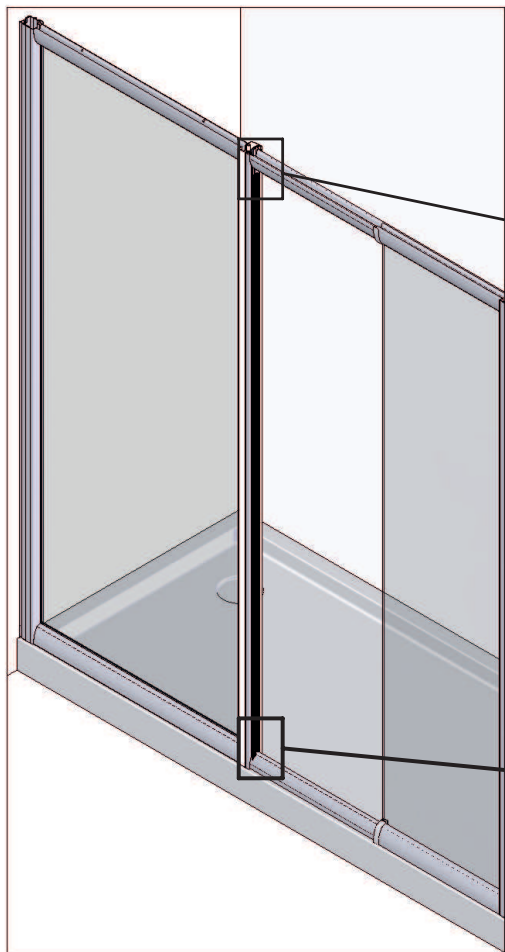

Voir annexe 2

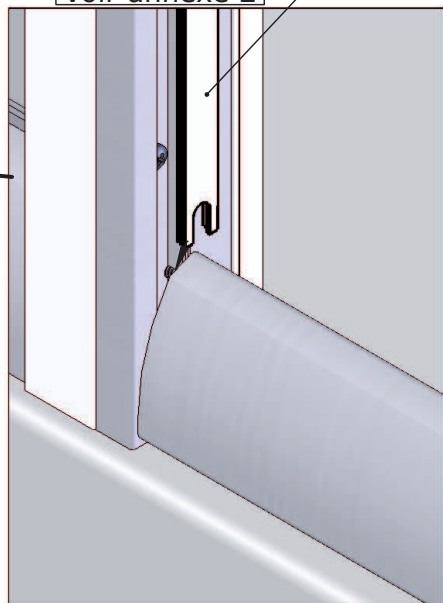

12

Ø3 mm

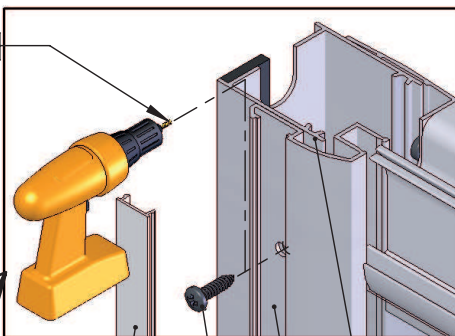

W

J

B

A

Voir annexe 2

Ø3 mm

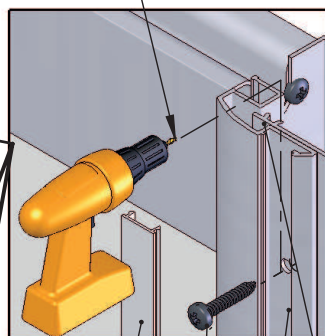

W

J

E

A

Voir annexe 2

Ajuster (W) si nécessaire.
Adjust (W) if necessary.

Vue de l'intérieur de la douche

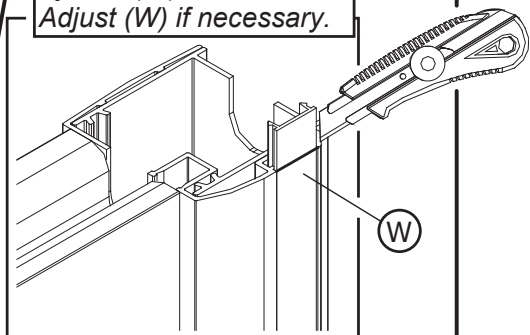

W

13

Positionner le joint (Q) sur le verre fixe.
Attach the seal (Q) to the fixed panel.

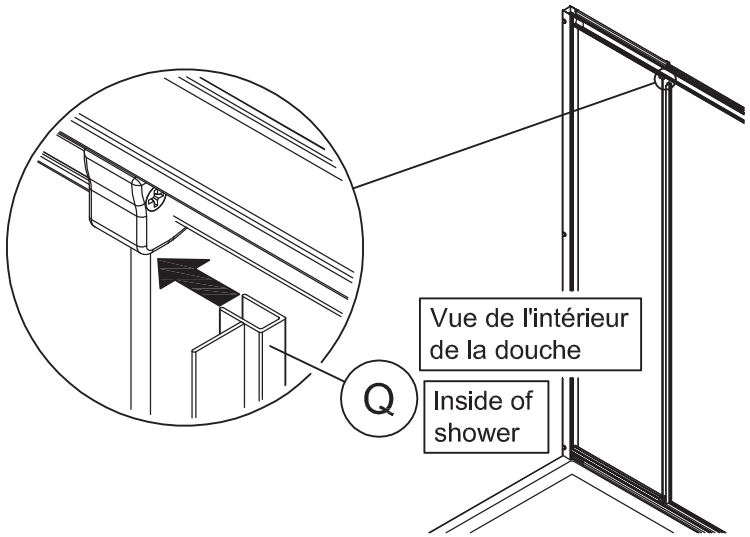

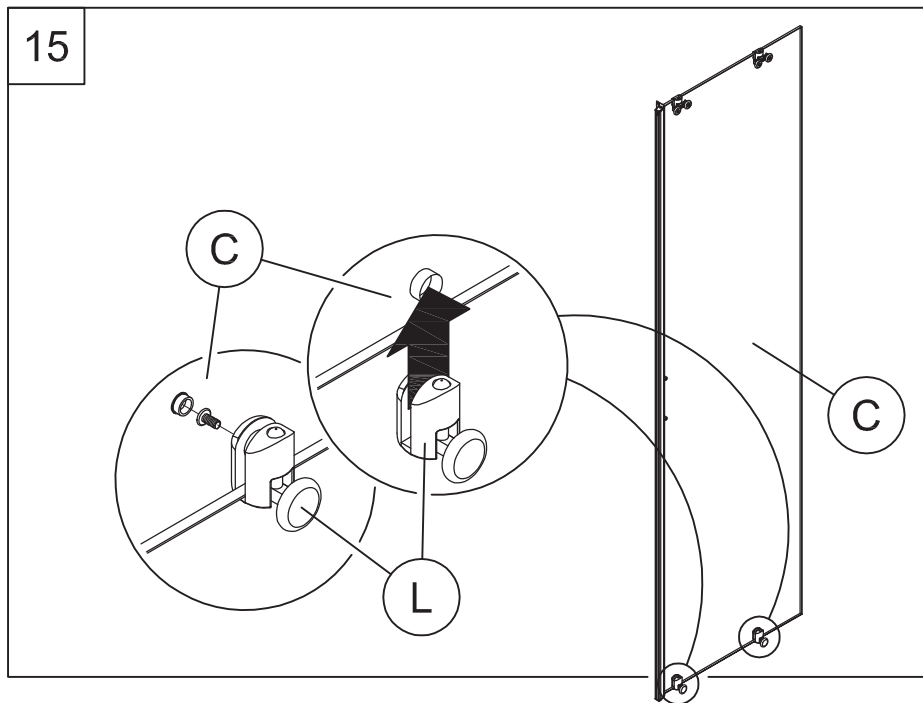
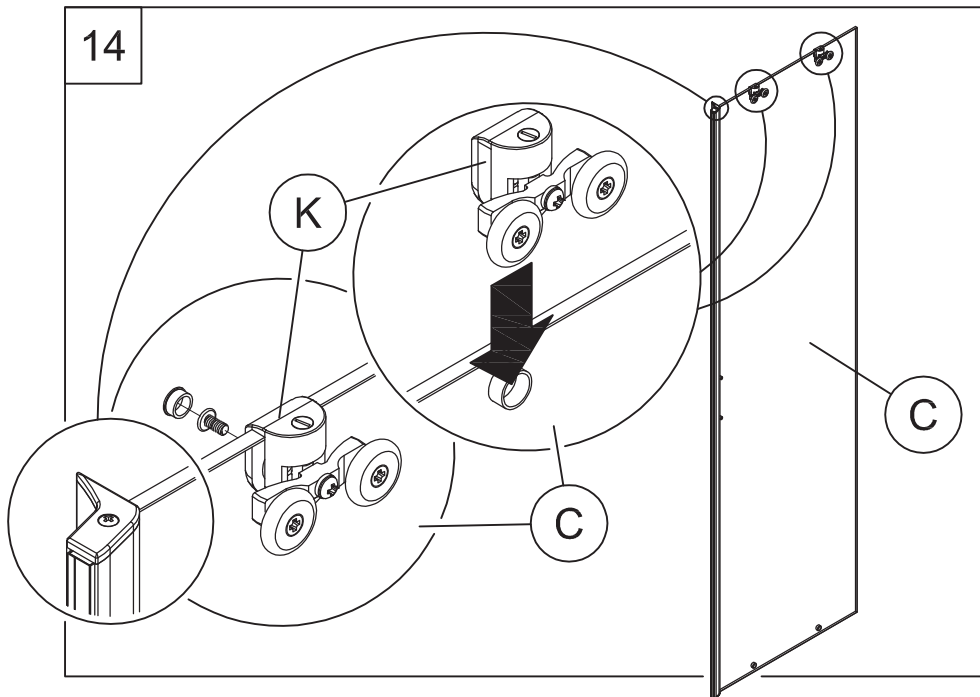

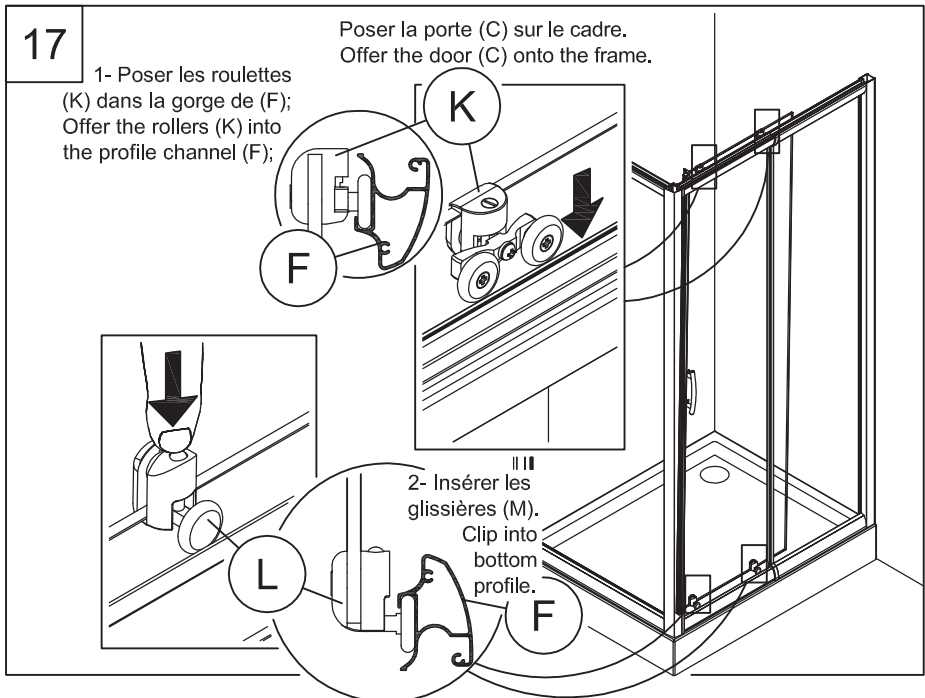
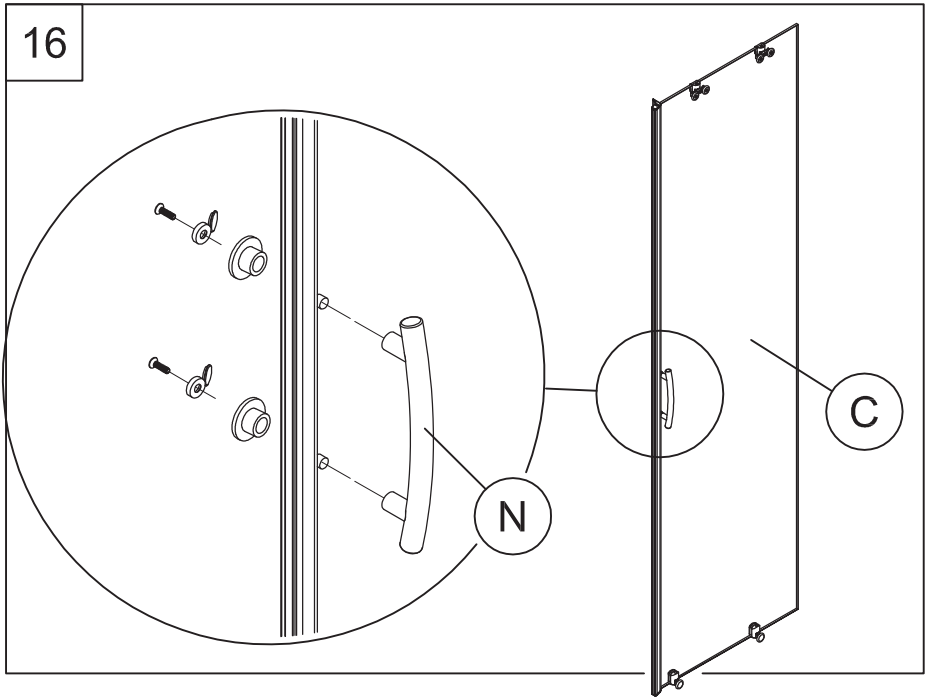

18

Réglage de la porte :
agir sur l'inclinaison de la porte en ajustant les vis des roulettes (K).
Adjust the door via the rollers (K).

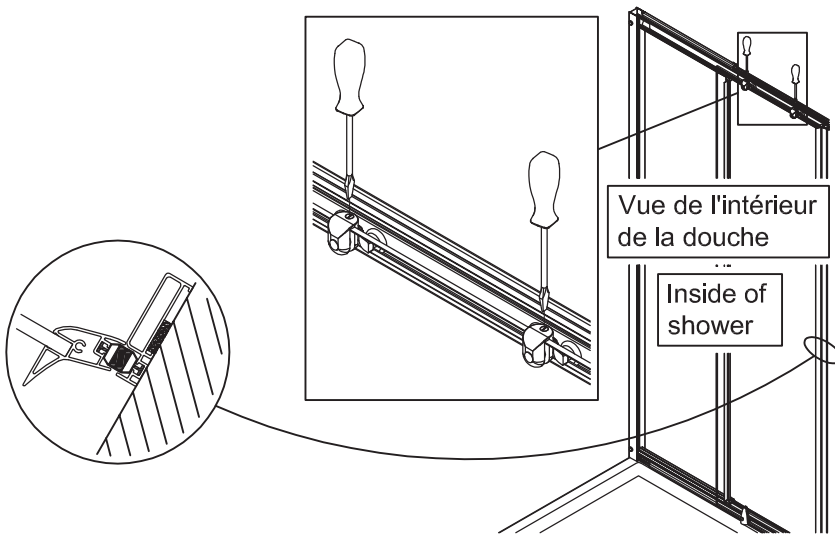

19

Ouvrir la porte de façon à avoir la poignée à 2,5 cm du verre fixe.
Open the door so that the door handle is 2.5cm from the fixed panel.

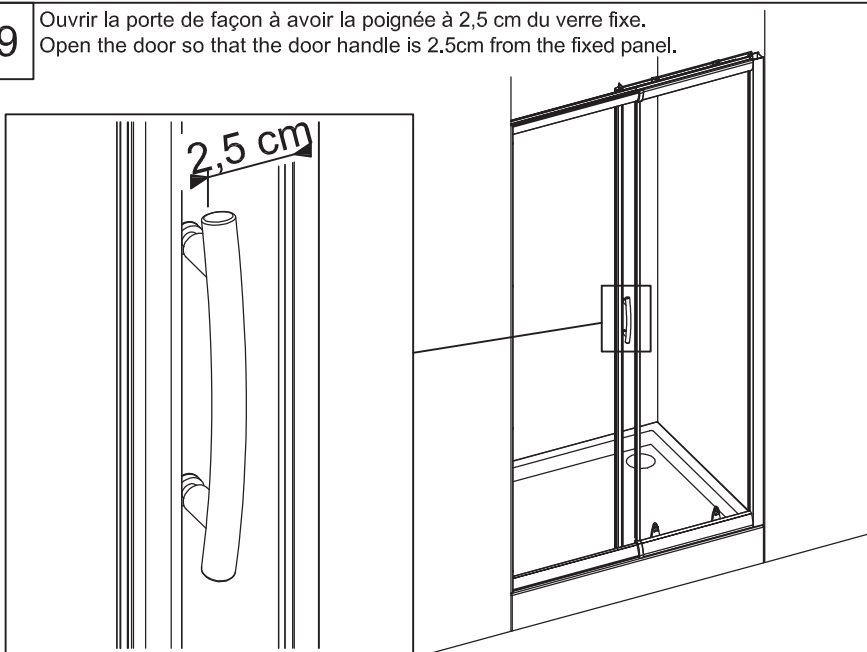

20

Fixer les butées (AB) afin :
 - de bloquer l'ouverture de la porte dans la position précédemment réglée,
 - et de bloquer les extensions (F).
 Fix the door stops so that it opens correctly.

⚠ Vérifier que les butées
 soient bien en contact avec
 les roues hautes et basses

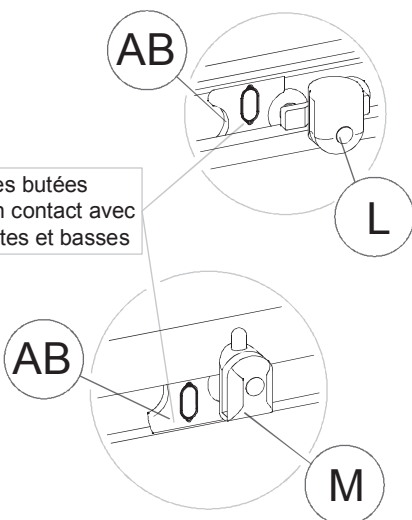

⚠ La vis traverse les deux profils.

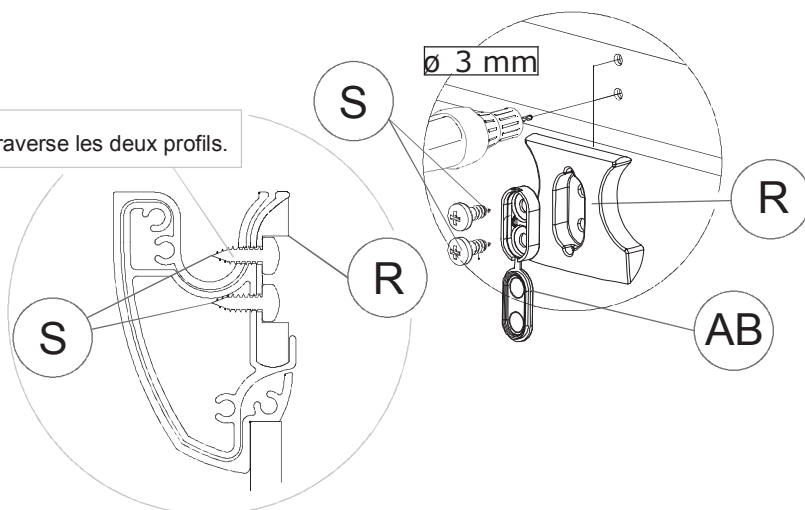

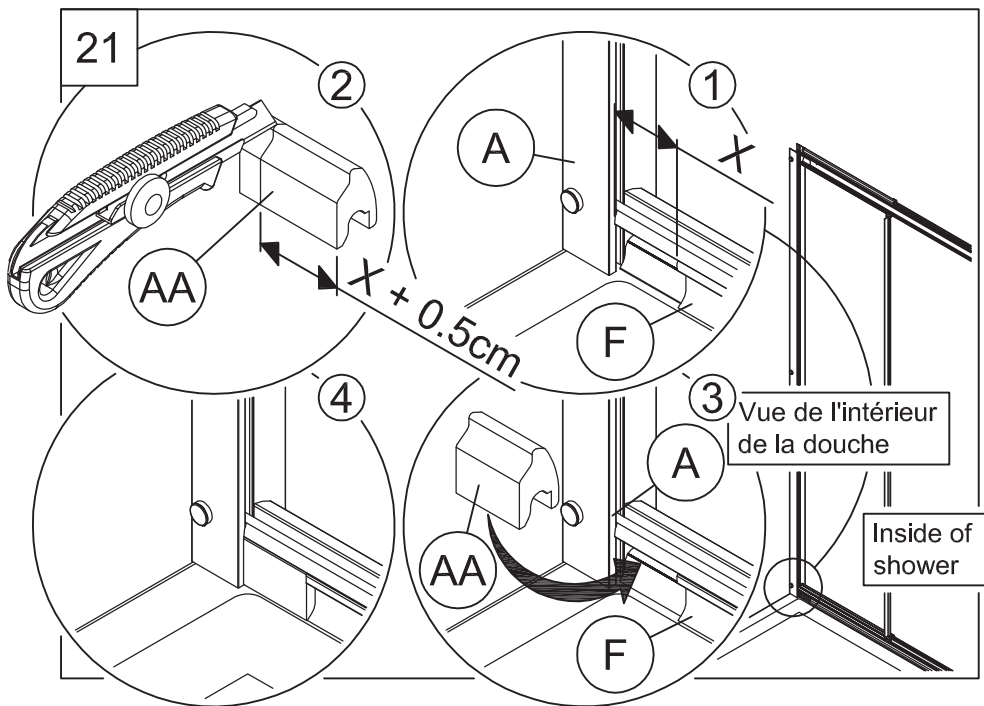

22

Y

Z

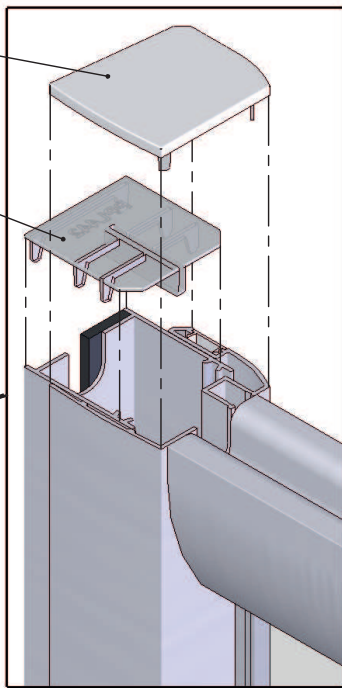

AE

AD

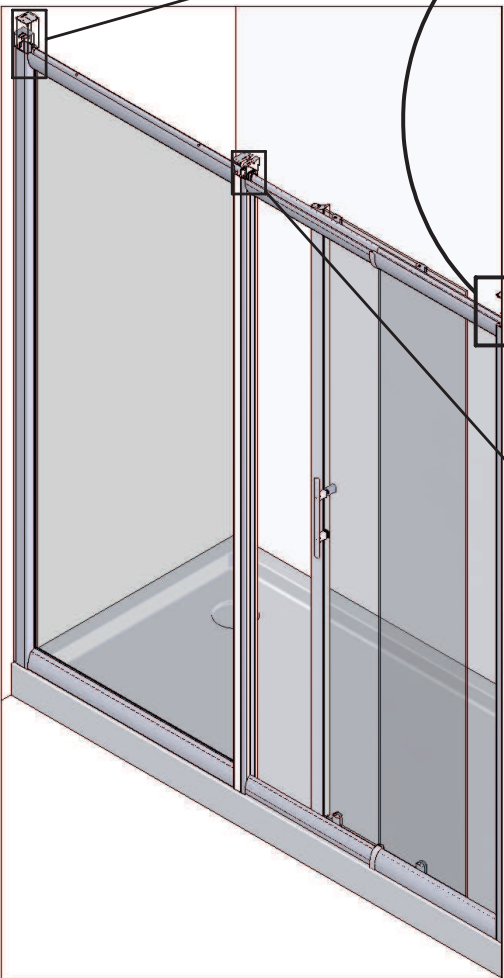
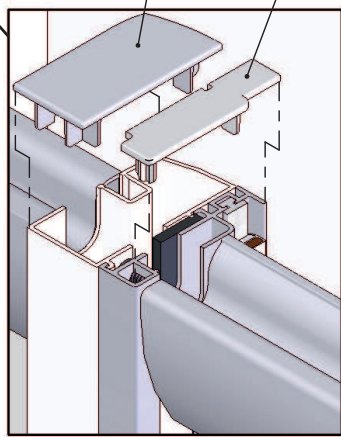

23

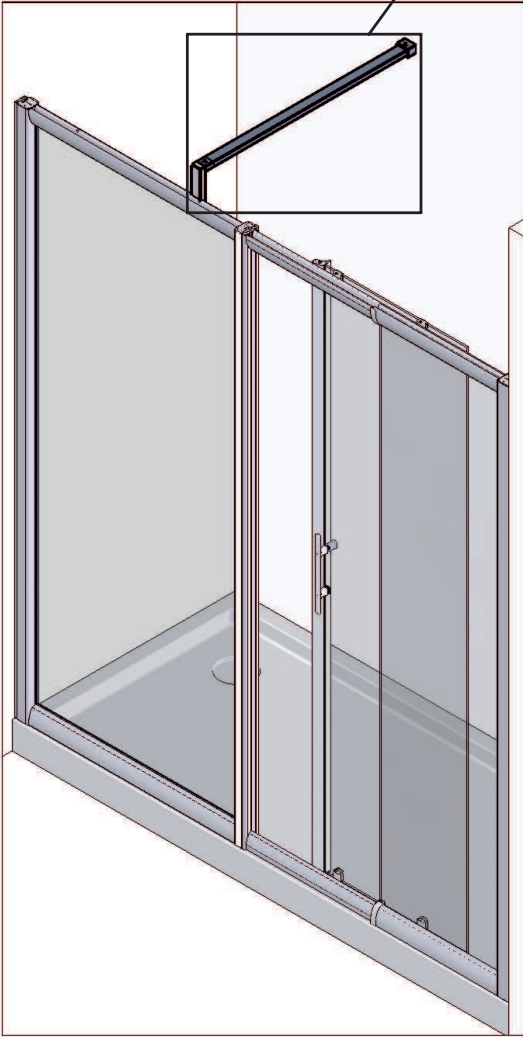
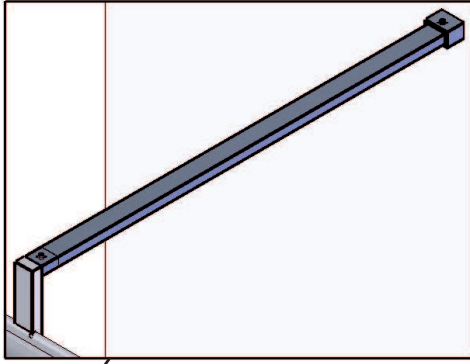

24

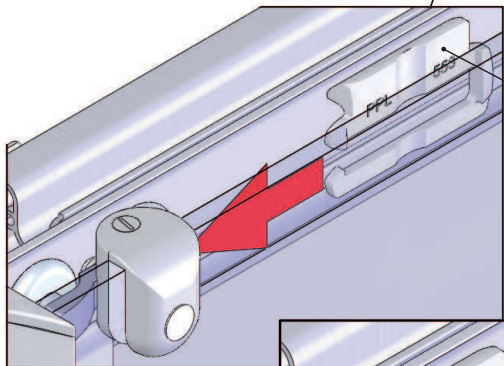
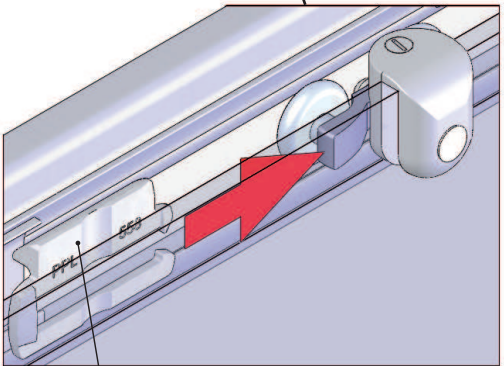
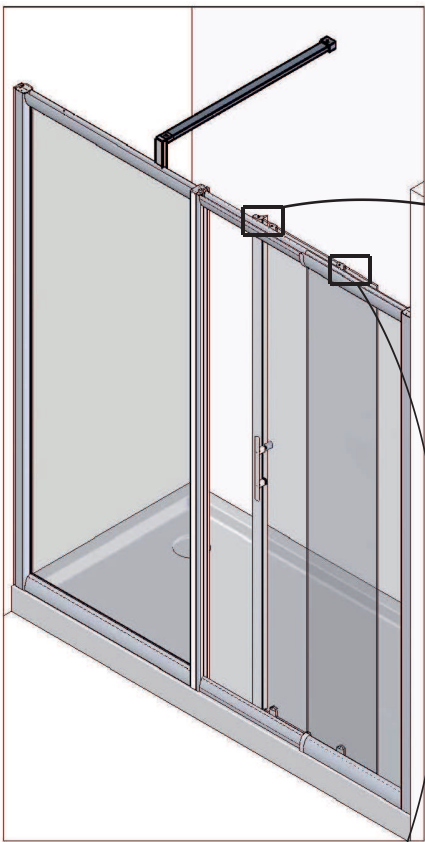

O
P

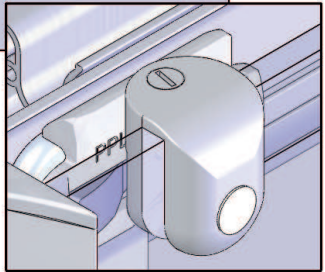
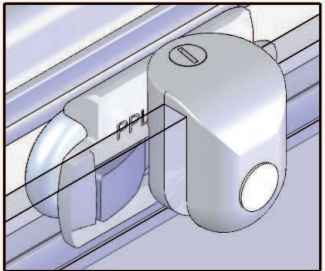

CONSEIL D'ENTRETIEN : *MAINTENANCE'S ADVICES :*

Pour votre confort d'utilisation, les vitrages des parois de douche sont traités avec une protection anti-calcaire.

Grâce à ce traitement, l'eau et les salissures glissent plus facilement sur le verre. Il devient plus facile et rapide de nettoyer les surfaces vitrées et les profilés aluminium.

Il est recommandé de les nettoyer à l'éponge avec des produits classiques de nettoyage non abrasifs. Vous ne devez pas utiliser de poudre et de crèmes abrasives, détergents chimiques, alcools trichloéthylène, éponges abrasives car il peuvent altérer le traitement de protection anticalcaire des parois en verre.

Rincer abondamment à l'eau clair, essuyer avec un chiffon doux.

For your comfort of use, all glass surfaces are treated with an anti liming protection.

This treatment aids glass cleaning by reducing the build up of lime scale. It becomes easier and faster to clean the glass and aluminium profiles.

Clean the glass using warm soapy water, rinse clean and dry with a clean cloth. Abrasive cleaners should not be used.

ANNEXE 1

APPENDICES 1

Gabarit de positionnement du joint (H)
Template for the correct positioning of the bottom
seal (H) when using a side panel

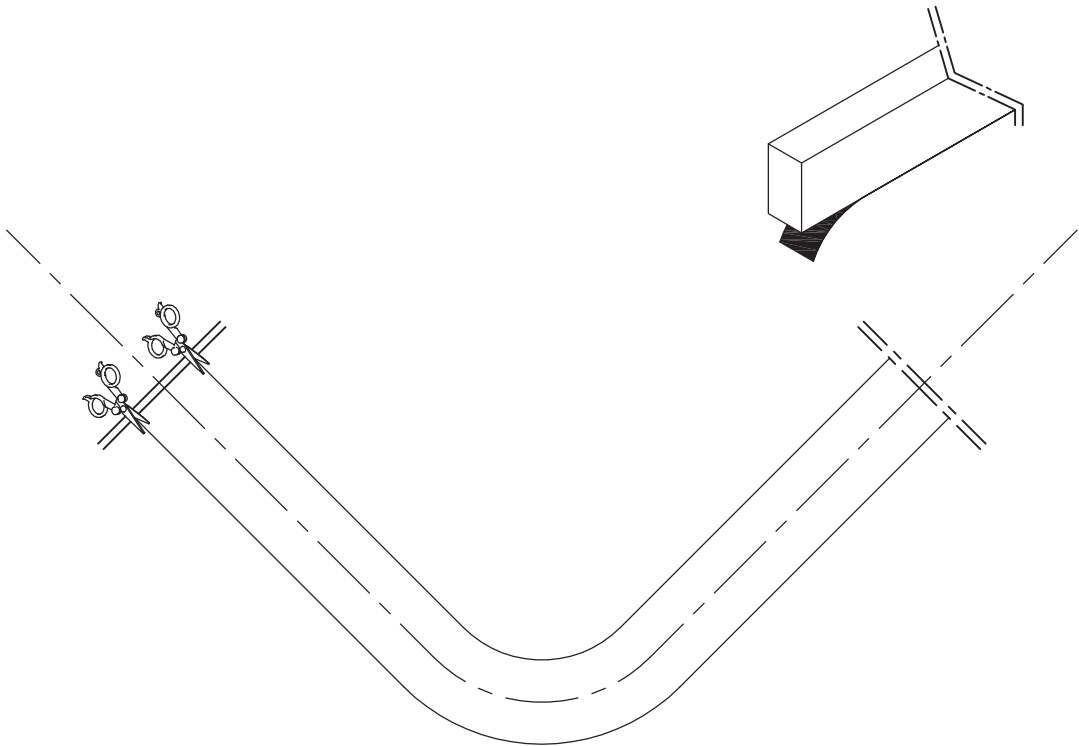

ECH : 1:1

ANNEXE 2 APPENDIX 2

Comment mettre les pièces de finition facilement.
How to put the finishing parts easily.

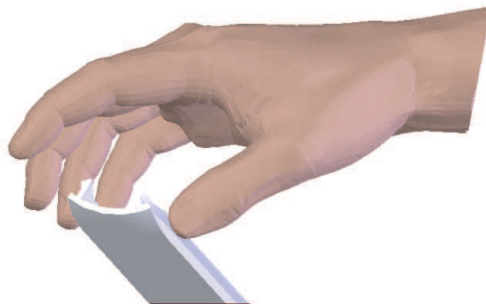
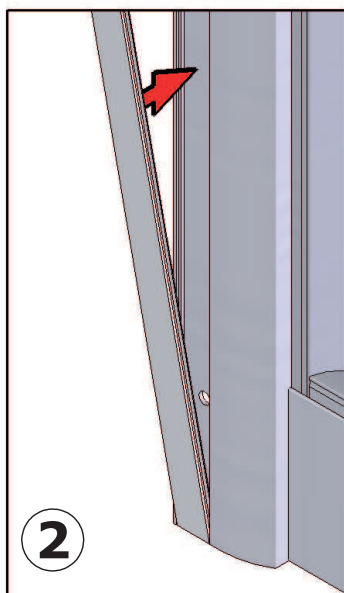
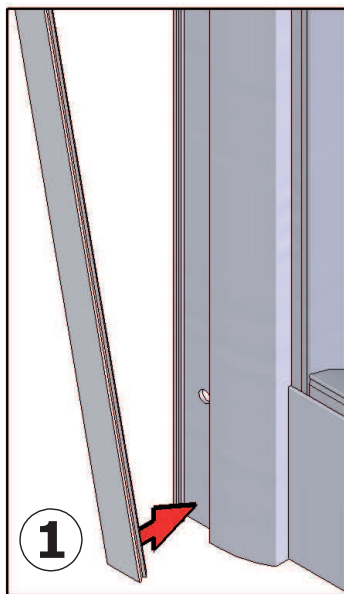

Si nécessaire, plier légèrement
l'extrémité.
If necessary, fold the end lightly.

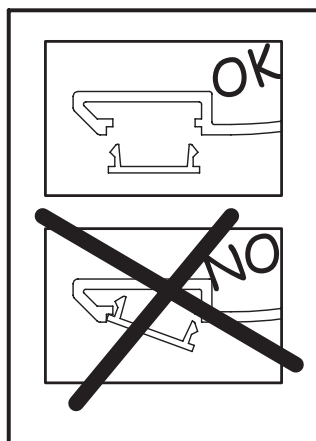



SAV

SERVICE HELPLINES

ASSISTENZA POST- VENDITA

SERVICIO POSTVENTA

FRANCE

02 40 21 29 45

UK

020 8842 0033

IRELAND

04697 33102

DEUTSCHLAND

0800 82 27 82 0

ITALIA

(0382) 6181

OSTEREICH

(0222) 21 402 16 0

SCHWEIZ

(01) 748 17 44

ESPANA

93 544 60 76

NEDERLAND

0475 487 100

BELGIE

+31 475 487 100

BELGIQUE

+31 475 487 100

РОССИЯ

963 19 40, 773 67 22



AQUAPRODUCTION, Site industriel, F - 44680 Chéméré

10

EN 14428

Paroi de douche, fabriquée en verre de silicate
sodo-calcique de sécurité trempé thermiquement

Aptitude au nettoyage : réussite

Résistance à l'impact/propriétés de fragmentation : réussite

Durée : réussite