

3017128m 03/12/12

01

03/12/12

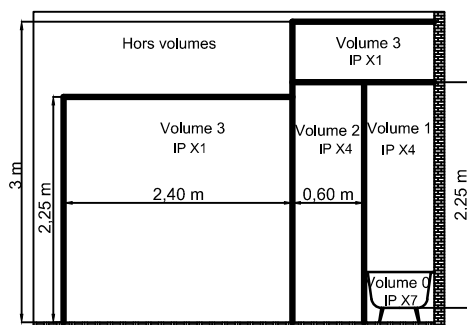
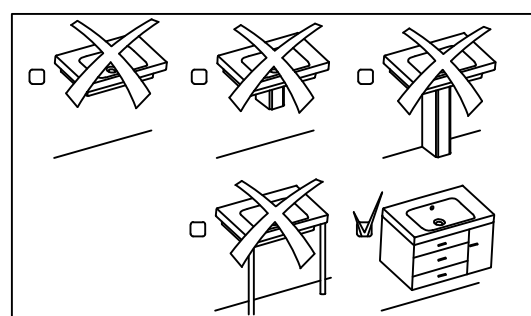
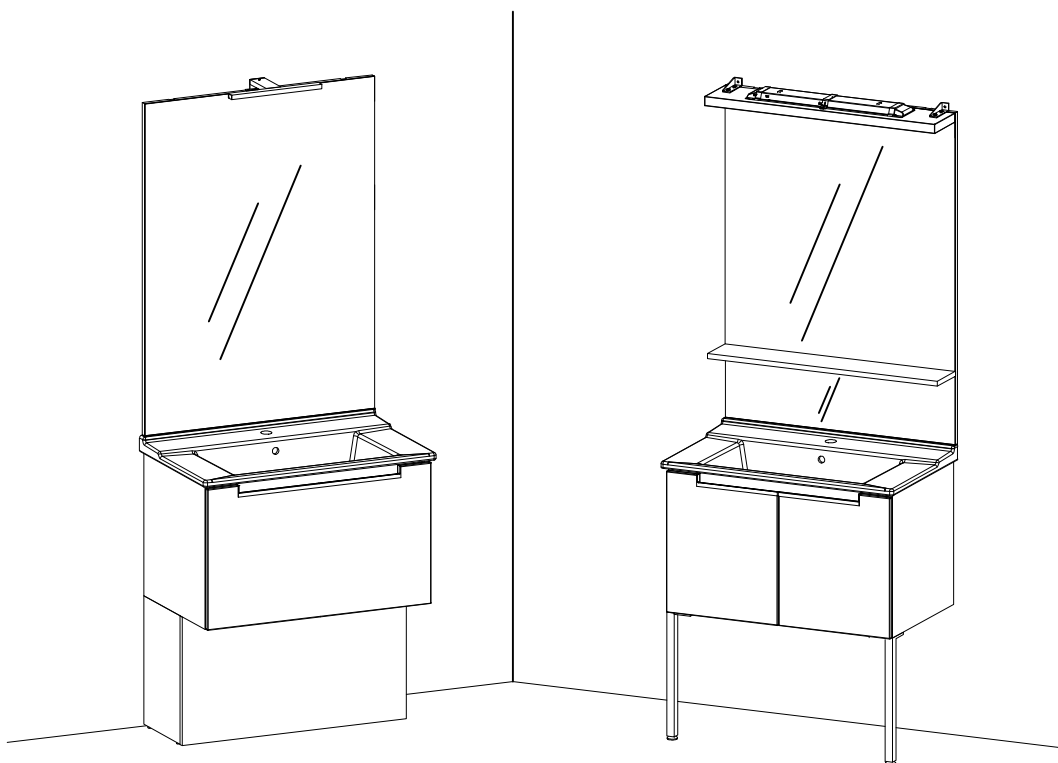

**Précaution:** couper le courant du circuit concerné ou de l'installation électrique lors du branchement

Cet appareil de classe II peut être installé dans les volumes 2 et 3 de la salle de bains (en aucun cas, il ne peut être installé au dessus de la baignoire ou dans le volume du bac à douche). Si l'appareil est équipé d'un socle 2P+T, celui ci doit impérativement se trouver dans le volume 3 (à plus de 0.60 m de la baignoire ou de la douche).



- (F) Cette notice est destinée à faciliter le montage du meuble, elle n'est pas contractuelle.
- (GB) Fitting instructions are intended to ease fitting. They are not subject to contract.
- (D) Unverbindliche Montageanleitung.
- (NL) Deze montagehandleiding is bedoeld om de montage te vereenvoudigen. Zij is niet bindend.
- (SP) Esta nota de instrucciones le ayudará a montar el mueble, no es contractual.
- (I) Le seguenti istruzioni sono destinate a facilitarvi il montaggio del mobile, e sono indicative.
- (P) Esta noticia é destinada a facilitar a montagem do móvel, não é contratual.
- Настоящие инструкции помогут вам проще и быстрее собрать мебель.
- (RUS) Производитель в любое время может внести изменения в изделие для улучшения качества и усовершенствования дизайна



- (F) Le choix des types de vis et chevilles, ainsi que la méthode de perçage pour les fixations murales sont fonction de la nature et de la qualité du mur et, de ce fait, relèvent de la seule responsabilité du poseur.
- (GB) Since the type of wall determines the fittings necessary for each unit, bolts and screws have not been supplied but left to the responsibility of the installer.
- (D) Das Befestigungsmaterial (Schrauben und Dübel), muss je nach Beschaffenheit der Wand (Mauerwerk, Gipskarton etc.) ausgewählt werden. Die Verantwortung für die einwandfreie Installation, übernimmt der Fachmann.
- (NL) Omdat de manier van bevestigen bepaald wordt door het type muur, zijn schroeven en pluggen niet inbegrepen en vallen onder de verantwoordelijkheid van de installateur.
- (SP) La elección del tipo de los torillos y clavijos y el modo de perforar la pared dependen de la naturaleza y de la calidad del muro y por esto dependen de la responsabilidad de la persona quien instala.
- (I) La scelta dei tipi di viti e tasselli, oltre che il sistema di foratura per il fissaggio murale sono da scegliere in funzione della struttura e qualità del muro, e per questo. La responsabilità spetta a chi esegue la posa.
- (P) A escolha do tipos de parafusos e cavilhas assim que o metodo de furar para colocar as fixacoes murais depende da natureza e da qualidade do muro, e de facto, atribuem a unica responsabilidade ao instalator.
- Поскольку каждая стена имеет свои особенности, крепеж для установки не поставляется. Специалист по сборке должен подобрать соответствующий тип креплений самостоятельно.
- (RUS)

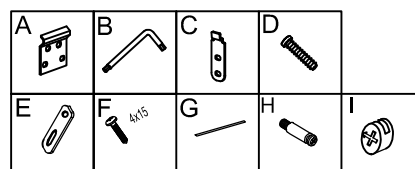
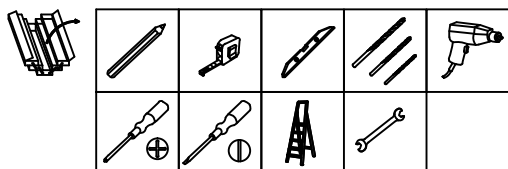
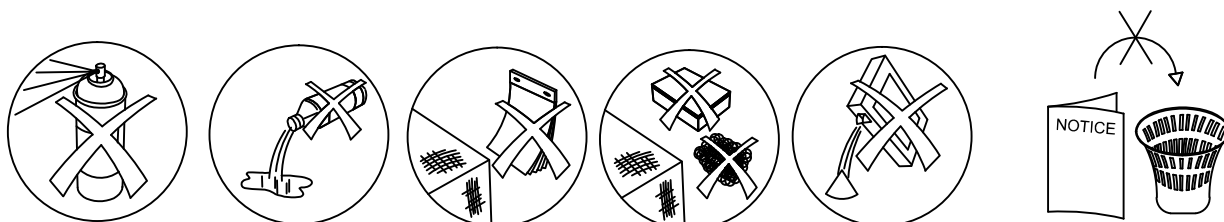

01

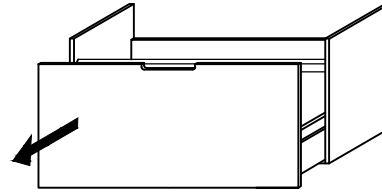
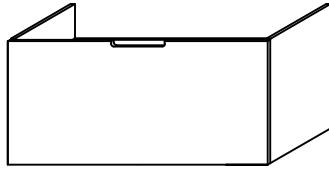
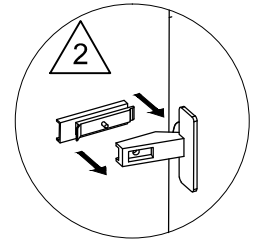
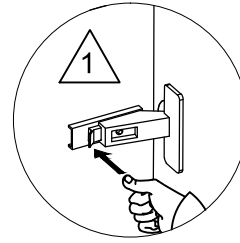
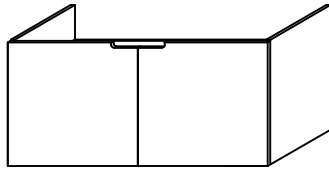

02

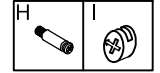
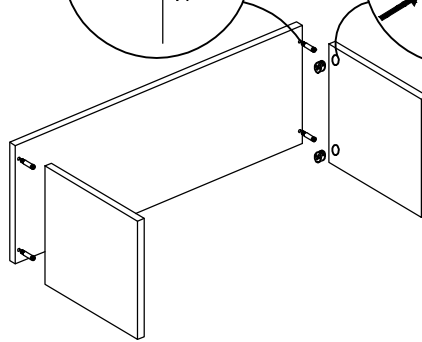
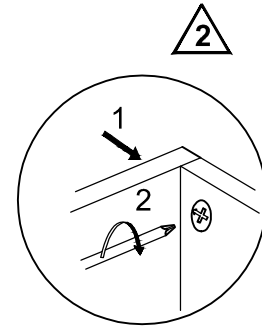
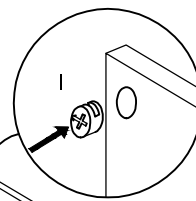
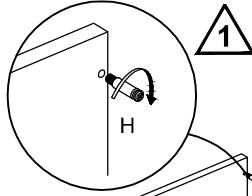

03

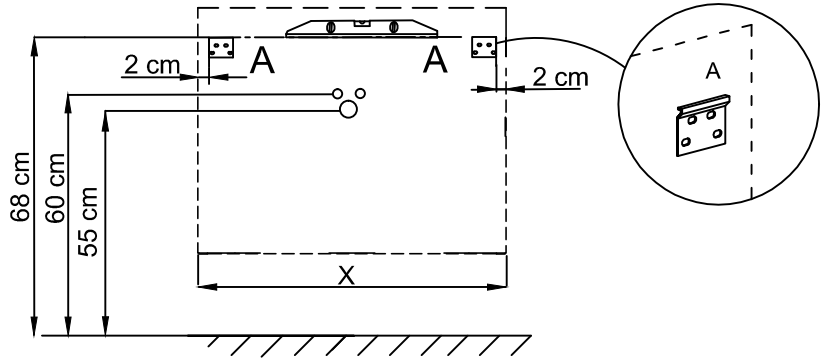
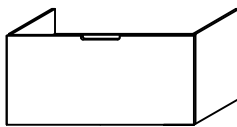
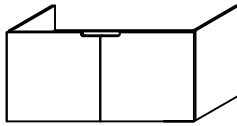

04

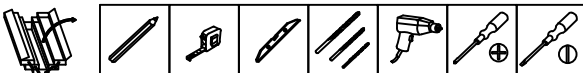
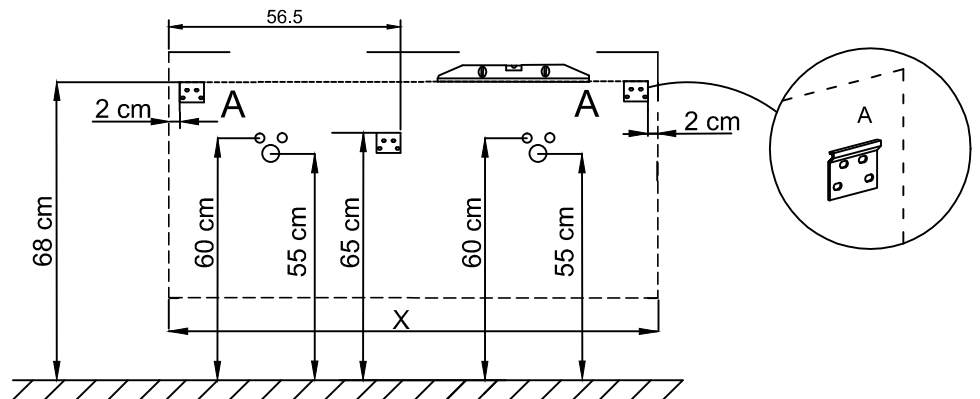
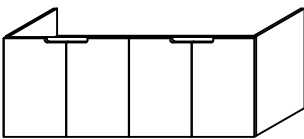

05

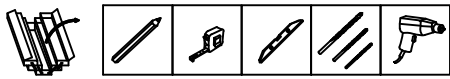
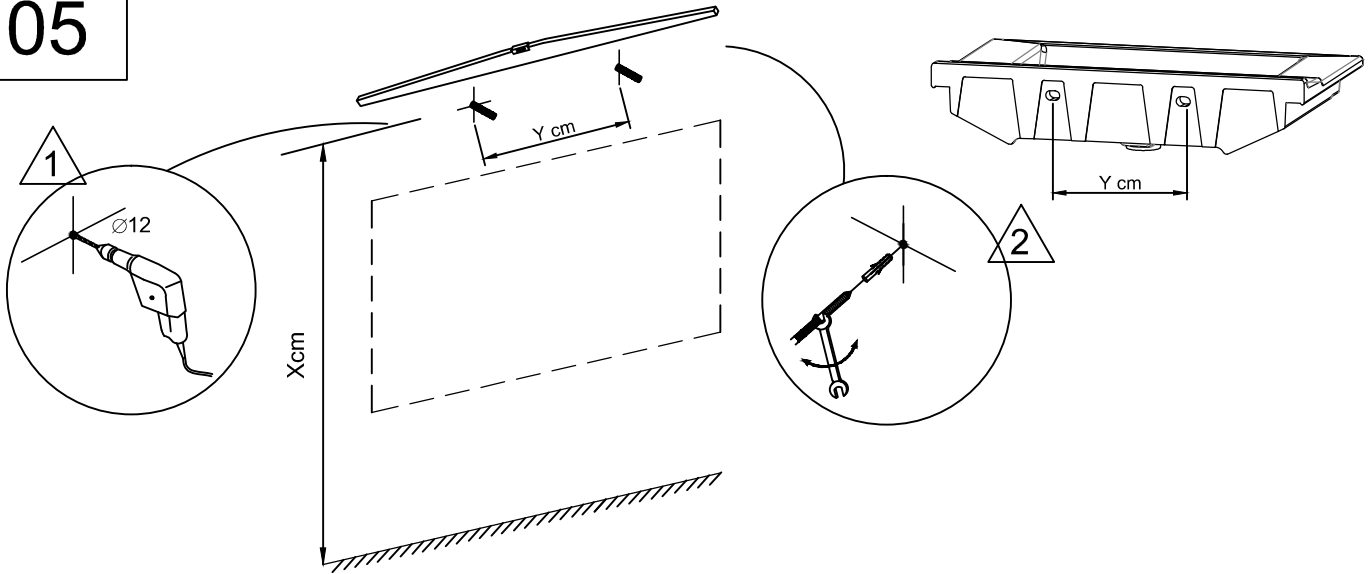

06

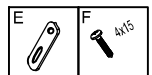
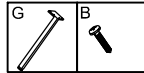
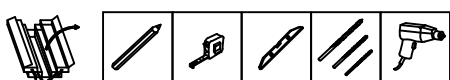
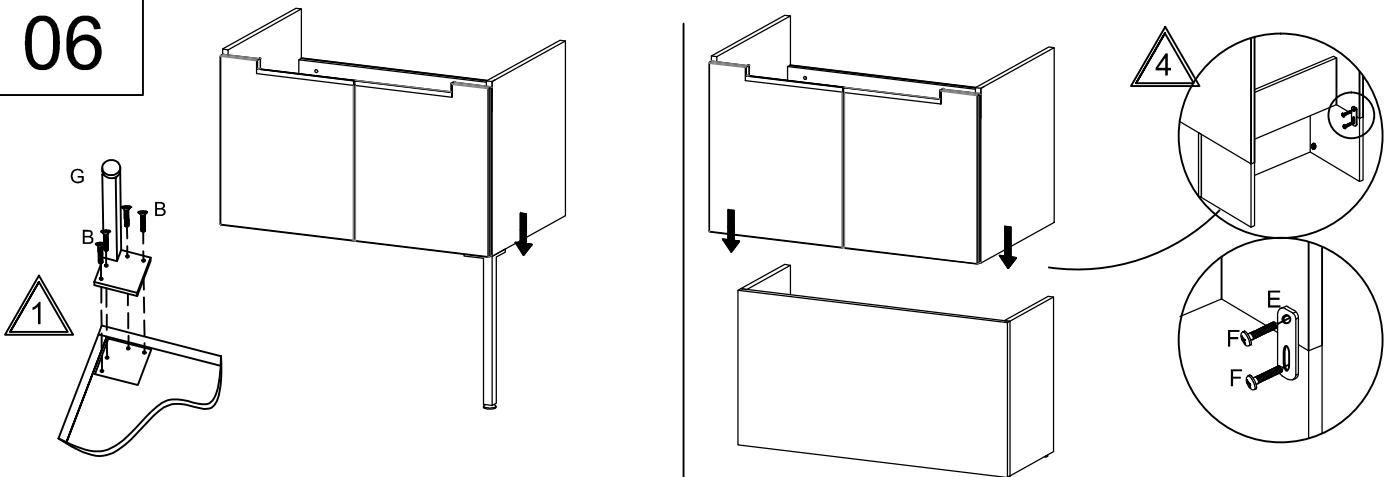

07

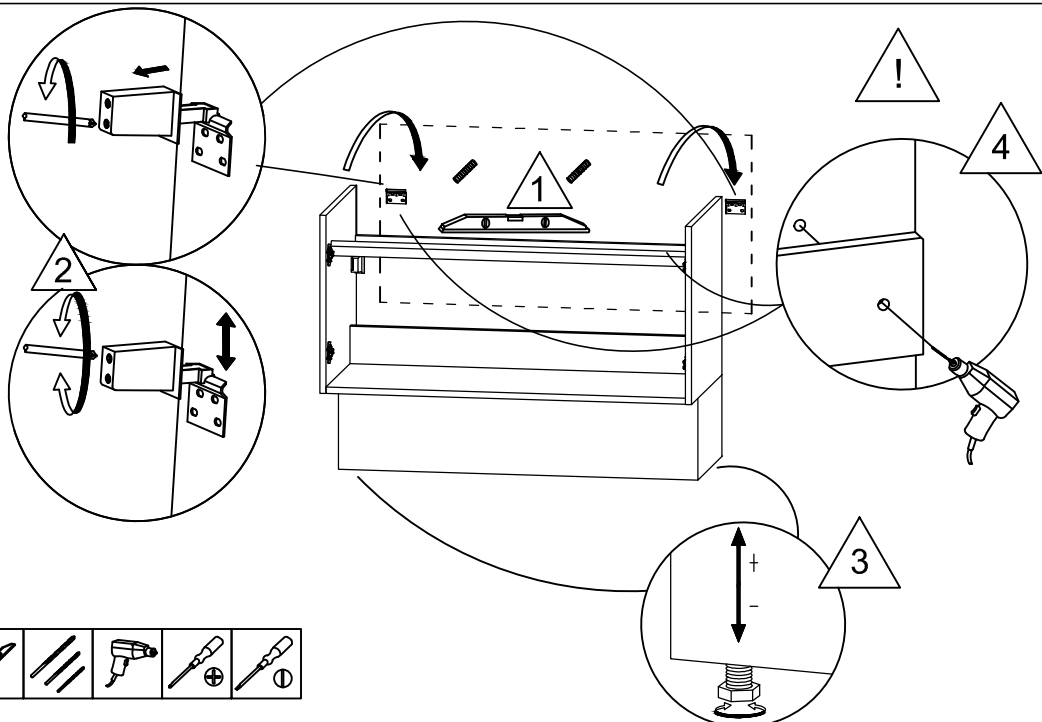

08

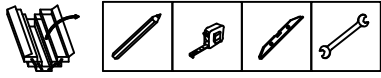
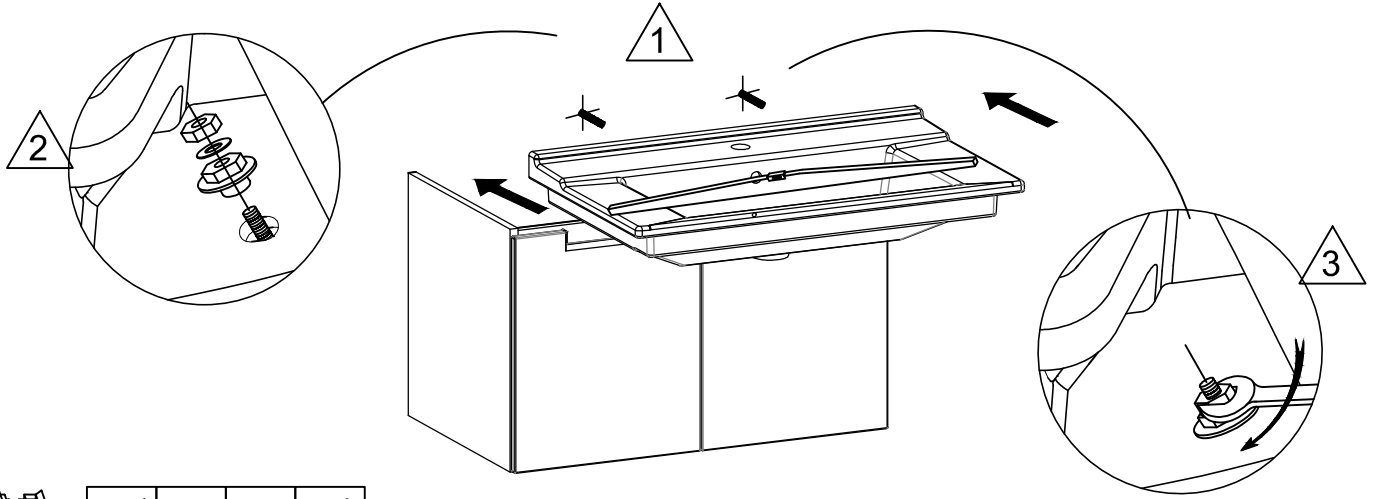

09

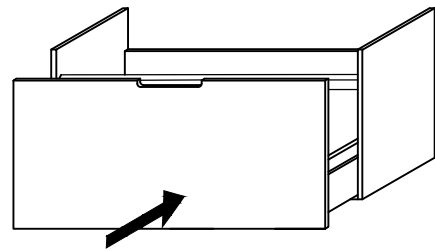
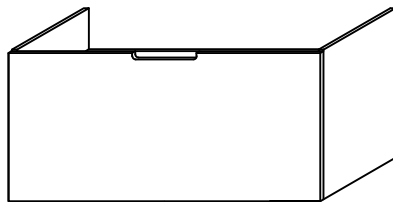
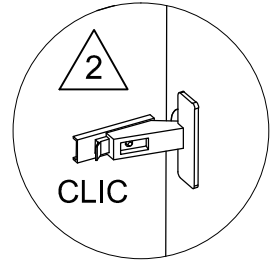
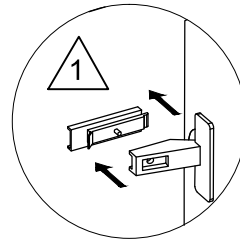
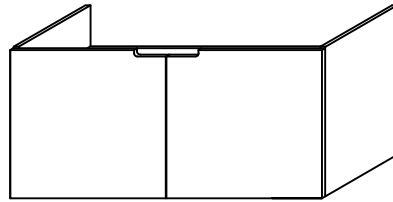

10

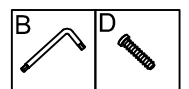
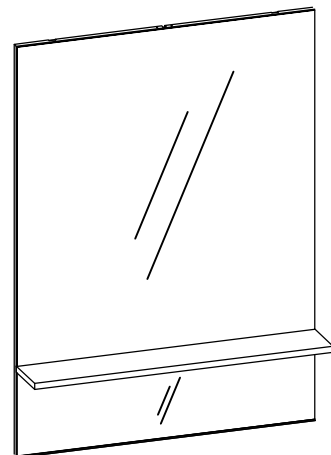
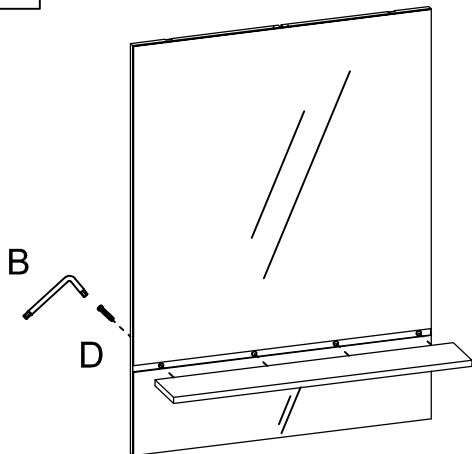

# 11

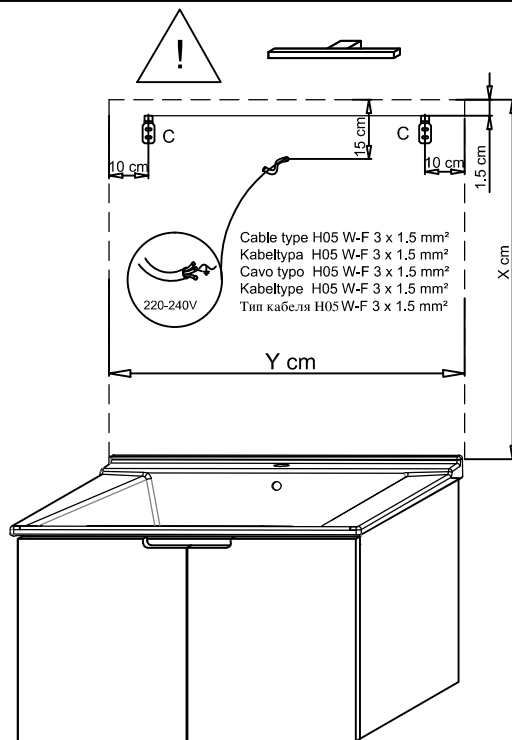
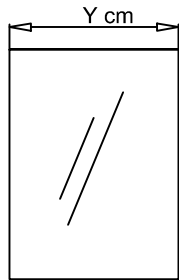
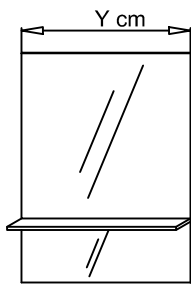

Cable type H05 W-F 3 x 1.5 mm<sup>2</sup>  
 Kabeltyp H05 W-F 3 x 1.5 mm<sup>2</sup>  
 Cavo tipo H05 W-F 3 x 1.5 mm<sup>2</sup>  
 Kabeltype H05 W-F 3 x 1.5 mm<sup>2</sup>  
 Тип кабеля H05 W-F 3 x 1.5 mm<sup>2</sup>

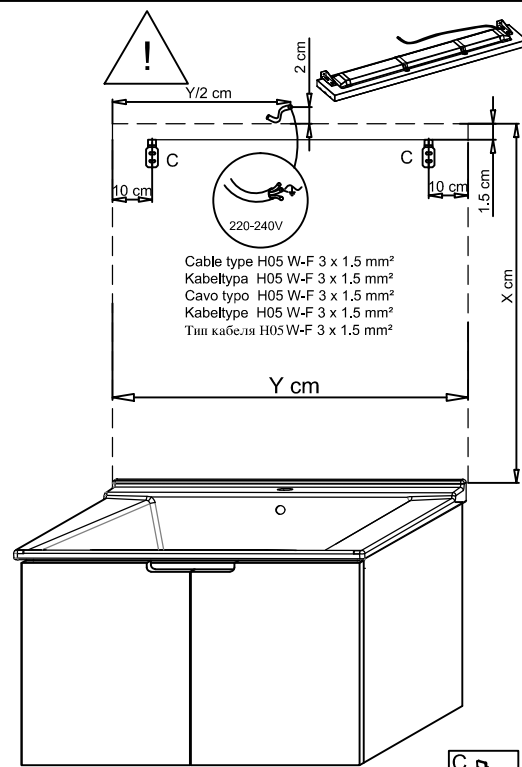

Cable type H05 W-F 3 x 1.5 mm<sup>2</sup>  
 Kabeltyp H05 W-F 3 x 1.5 mm<sup>2</sup>  
 Cavo tipo H05 W-F 3 x 1.5 mm<sup>2</sup>  
 Kabeltype H05 W-F 3 x 1.5 mm<sup>2</sup>  
 Тип кабеля H05 W-F 3 x 1.5 mm<sup>2</sup>

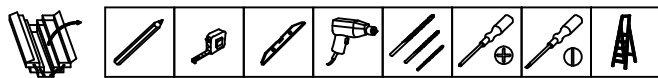

# 12

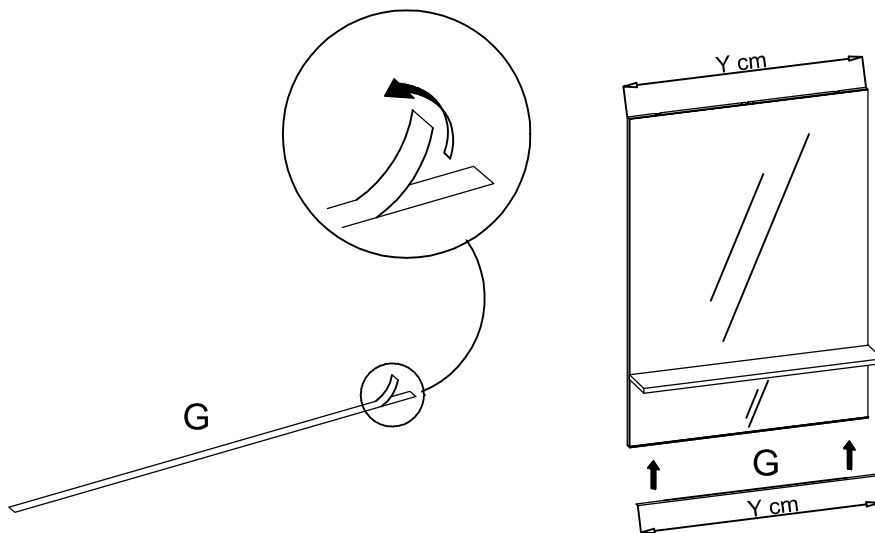

# 13

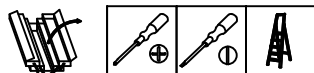
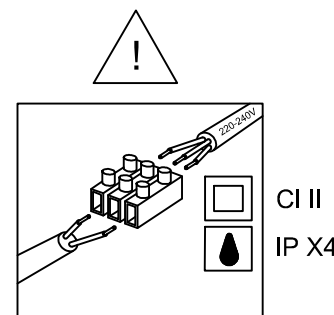
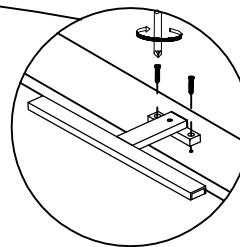
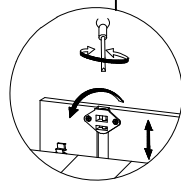
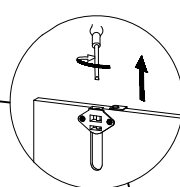
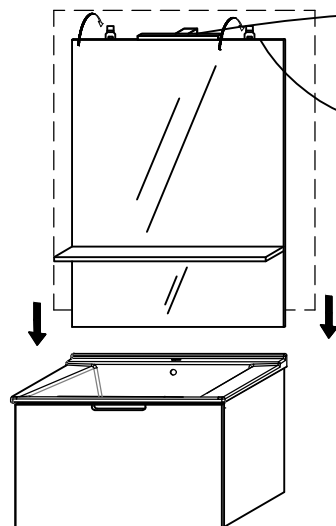

**JACOB DELAFON España**

Ctra. Logroño, km 17

50629 SOBRADIEL

ZARAGOZA

<http://www.jacobdelafon.com/es/index.jde>

Tél : +34 902 46 46 86

**KOHLER / JACOB DELAFON**

207, Angle Boulevard d'Anfa

20 000 CASABLANCA

<http://www.jacobdelafon.com/ma/index.jdf>

Tél : +212 2 295 9740

**KOHLER UK**

Cromwell Road

Cheltenham

GL525EP Gloucestershire

UNITED KINGDOM

<http://www.kohler.co.uk>

Tél : +44 (0)844 571 0048

**KOHLER ITALIA KITCHEN AND BATH srl**

via Roma 108

centro direzionale Cassina Plaza

edificio B - scala 2

20060 Cassina de Pecchi (Mi)

<http://www.kohleritalia.it>

Tel : +39 02 94437100

**KOHLER DEUTSCHLAND**

Kohler GmbH

Holtgrade 30

45739 Oer-Erkenschwick

[www.kohlerco.de](http://www.kohlerco.de)

Tel: +49 2368 91 87-87

**KOHLER MIDDLE EAST**

Al Thuraya Tower 2

9th Floor, Office 905

P.O. Box 500431

DIC, Dubai, UAE

<http://www.me.kohler.com/eu/index.htm>

Tél : +971-4-3624650

**КОЛЕР РУС / KOHLER RUS**

Ул. 1-я Бородинская, д.2а

Офис 147

121059 МОСКВА

РОССИЯ

<http://www.jacobdelafon.ru>

Тел.: +7 495 783 5223

14

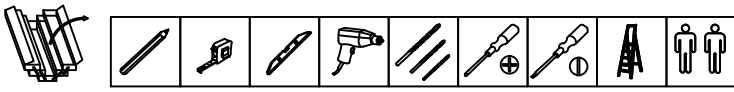
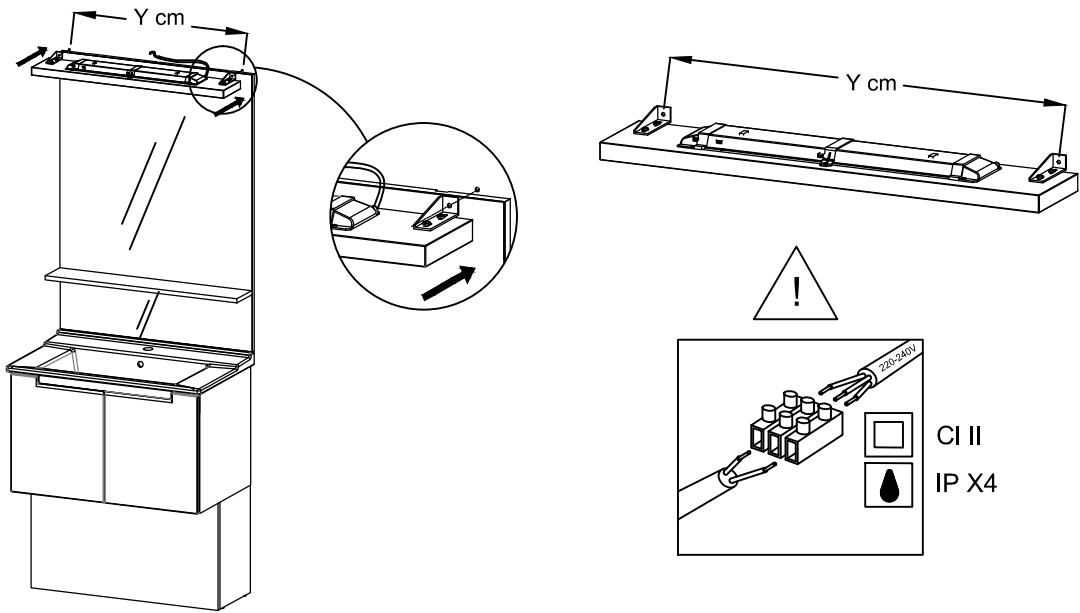

15

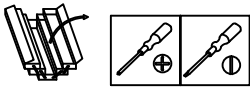
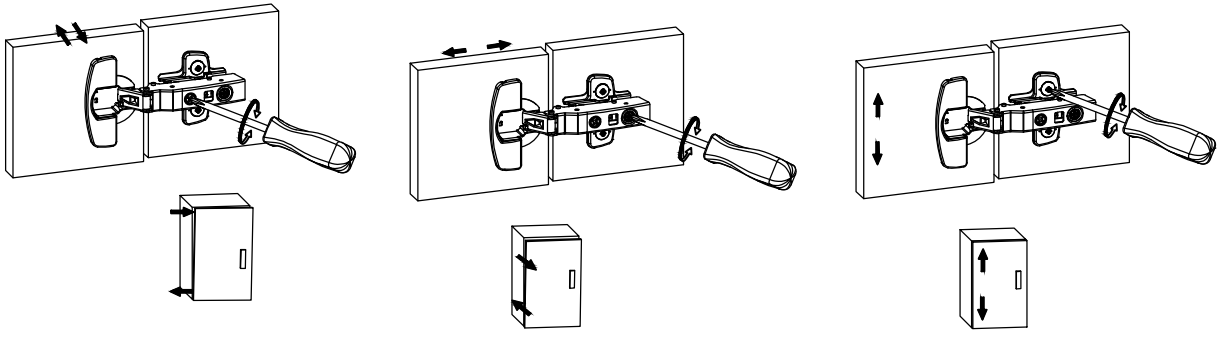

16

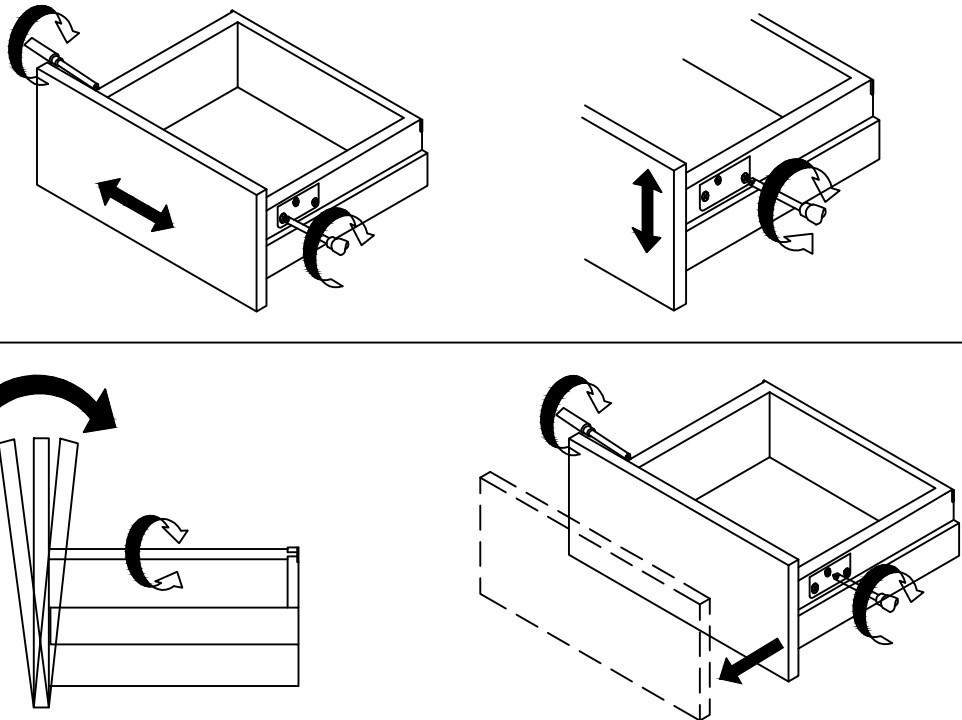

3024700m 24/11/14

03

30/03/16

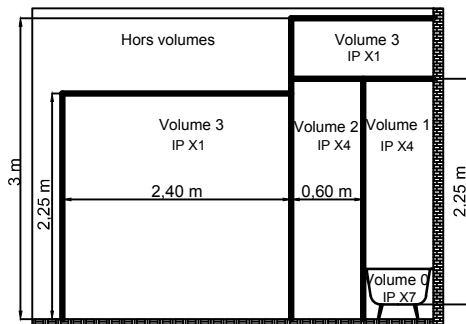
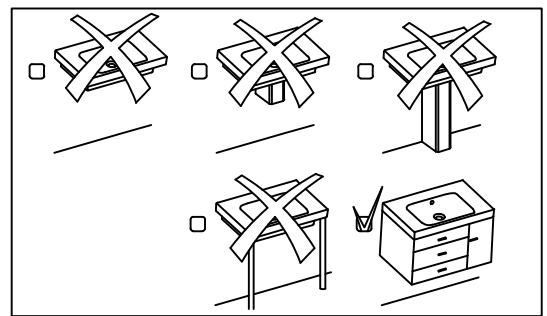
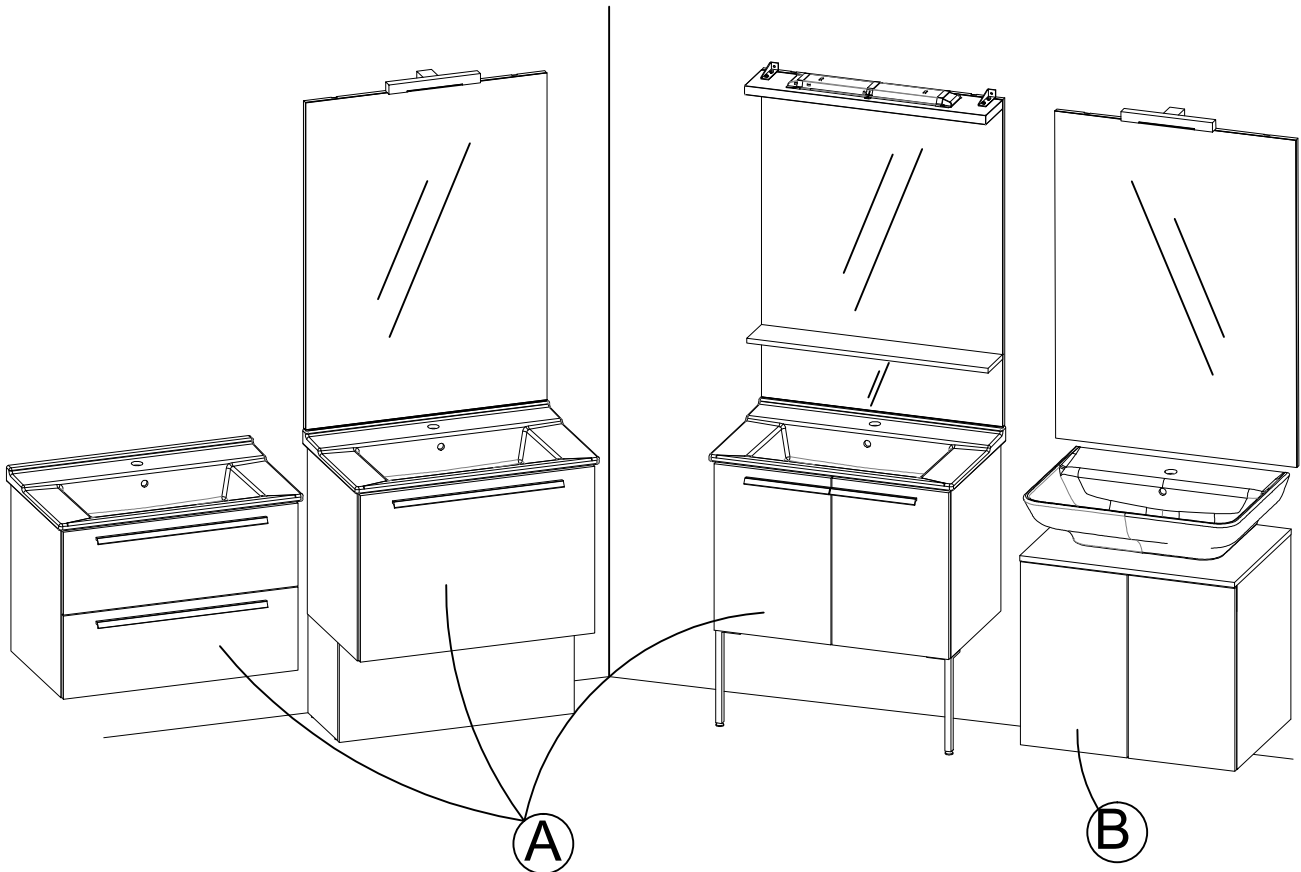

**Précaution:** couper le courant du circuit concerné ou de l'installation électrique lors du branchement

Cet appareil de classe II peut être installé dans les volumes 2 et 3 de la salle de bains (en aucun cas, il ne peut être installé au dessus de la baignoire ou dans le volume du bac à douche). Si l'appareil est équipé d'un socle 2P+T, celui ci doit impérativement se trouver dans le volume 3 (à plus de 0.60 m de la baignoire ou de la douche).



- (F) Cette notice est destinée à faciliter le montage du meuble, elle n'est pas contractuelle.
- (GB) Fitting instructions are intended to ease fitting. They are not subject to contract.
- (D) Unverbindliche Montageanleitung.
- (NL) Deze montagehandleiding is bedoeld om de montage te vereenvoudigen. Zij is niet bindend.
- (SP) Esta nota de instrucciones le ayudará a montar el mueble, no es contractual.
- (I) Le seguenti istruzioni sono destinate a facilitarvi il montaggio del mobile, e sono indicative.
- (P) Esta notícia é destinada a facilitar a montagem do móvel, não é contratual.
- (RUS) Інструкція зmontажу є допоміжною і не є договірною. Вона не є гарантією на меблі.



- (F) Le choix des types de vis et chevilles, ainsi que la méthode de perçage pour les fixations murales sont fonction de la nature et de la qualité du mur et, de ce fait, relèvent de la seule responsabilité du poseur.
- (GB) Since the type of wall determines the fittings necessary for each unit, bolts and screws have not been supplied but left to the responsibility of the installer.
- (D) Das Befestigungsmaterial (Schrauben und Dübel), muss je nach Beschaffenheit der Wand (Mauerwerk, Gipskarton etc.) ausgewählt werden. Die Verantwortung für die einwandfreie Installation, übernimmt der Fachmann.
- (NL) Omdat de manier van bevestigen bepaald wordt door het type muur, zijn schroeven en pluggen niet inbegrepen en vallen onder de verantwoordelijkheid van de installateur.
- (SP) La elección del tipo de los torillos y claviros y el modo de perforar la pared dependen de la naturaleza y de la calidad del muro y por esto dependen de la responsabilidad de la persona quien instala.
- (I) La scelta dei tipi di viti e tasselli, oltre che il sistema di foratura per il fissaggio murale sono da scegliere in funzione della struttura e qualità del muro, e per questo. La responsabilità spetta a chi esegue la posa.
- (P) A escolha do tipos de parafusos e cavilhas assim que o metodo de furar para colocar as fixacoes murais depende da natureza e da qualidade do muro, e de facto, atribuem a unica responsabilidade ao instalator.
- (RUS) Вибір типів шурупів та вставок, а також метод свердління для кріплення до стіни залежить від природи та якості стіни, тому відповідальність за правильну установку покладена на установника.

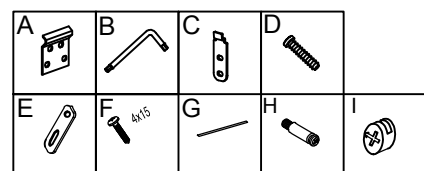
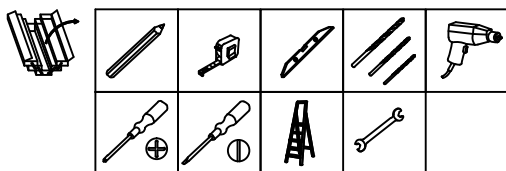
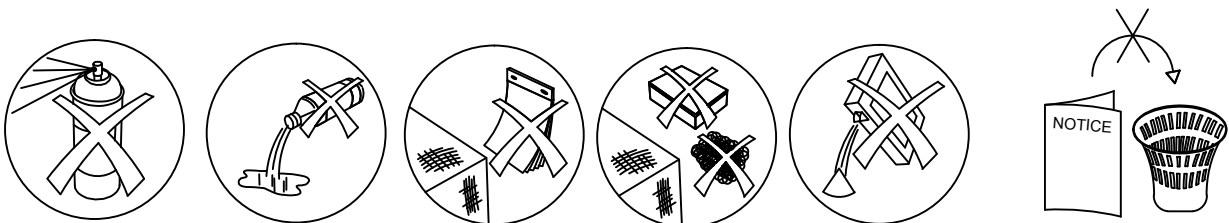

A

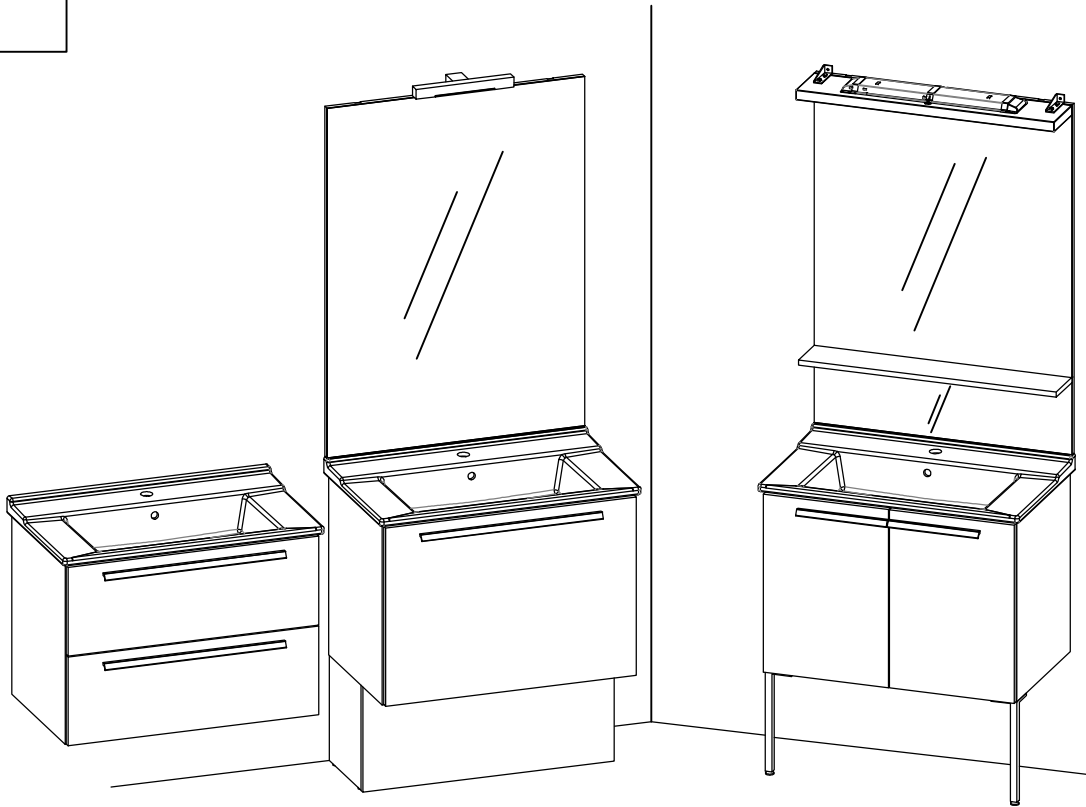

01A

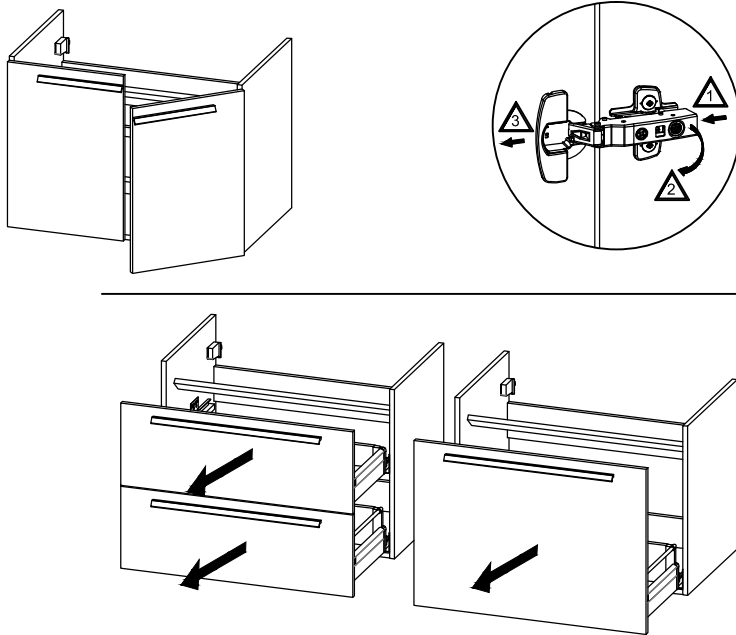

02A

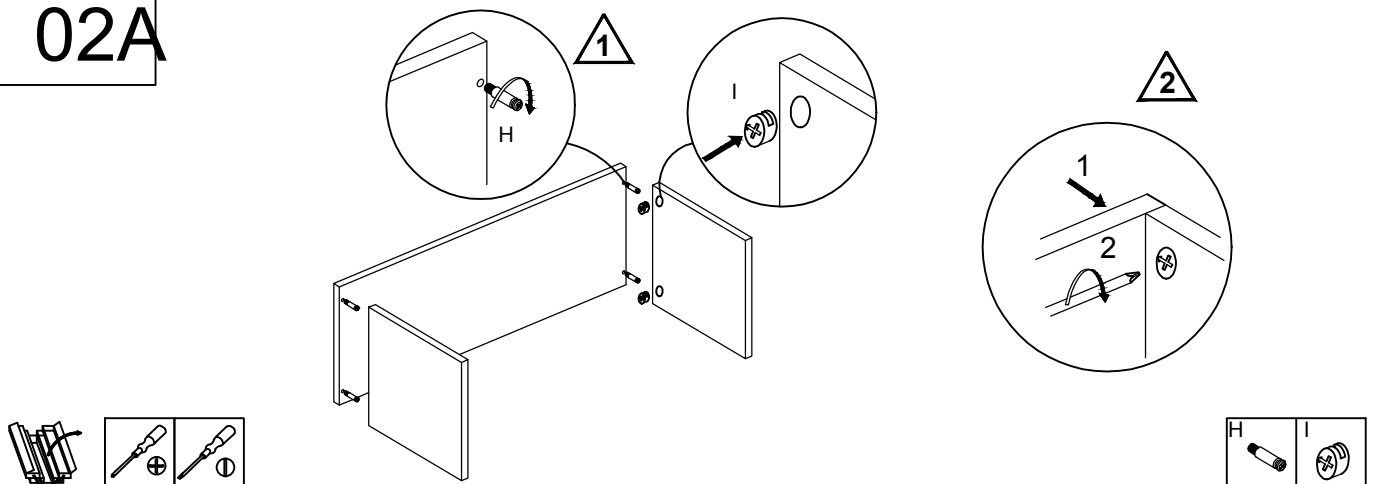

# 03A

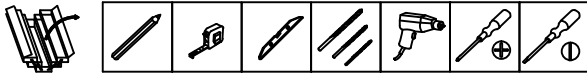
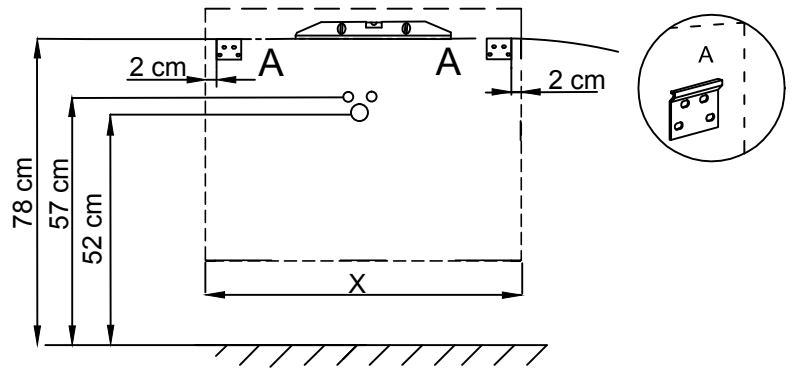
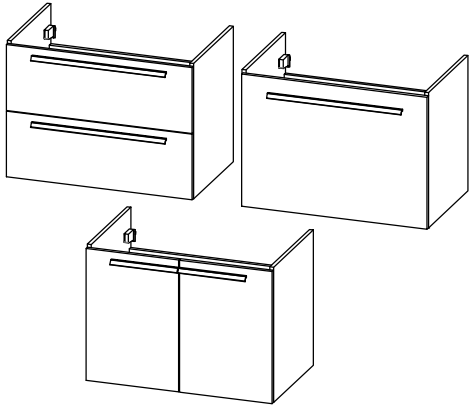

# 04A

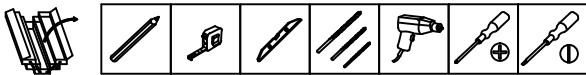
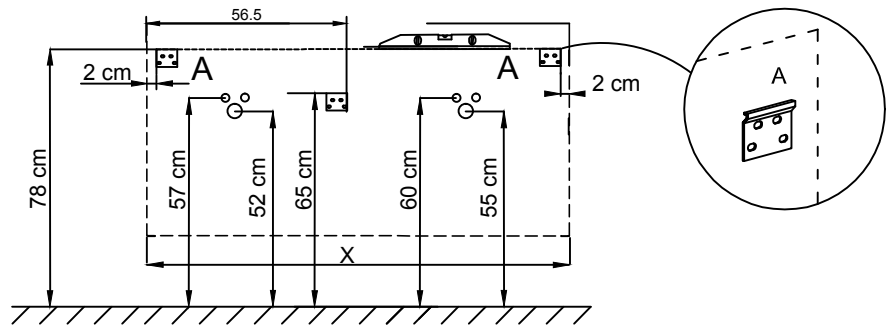
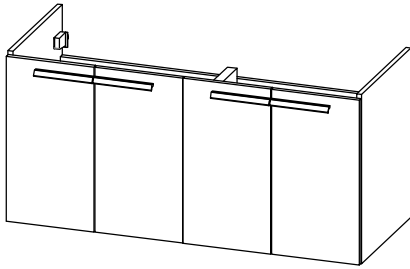

# 05A

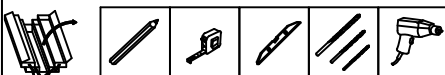
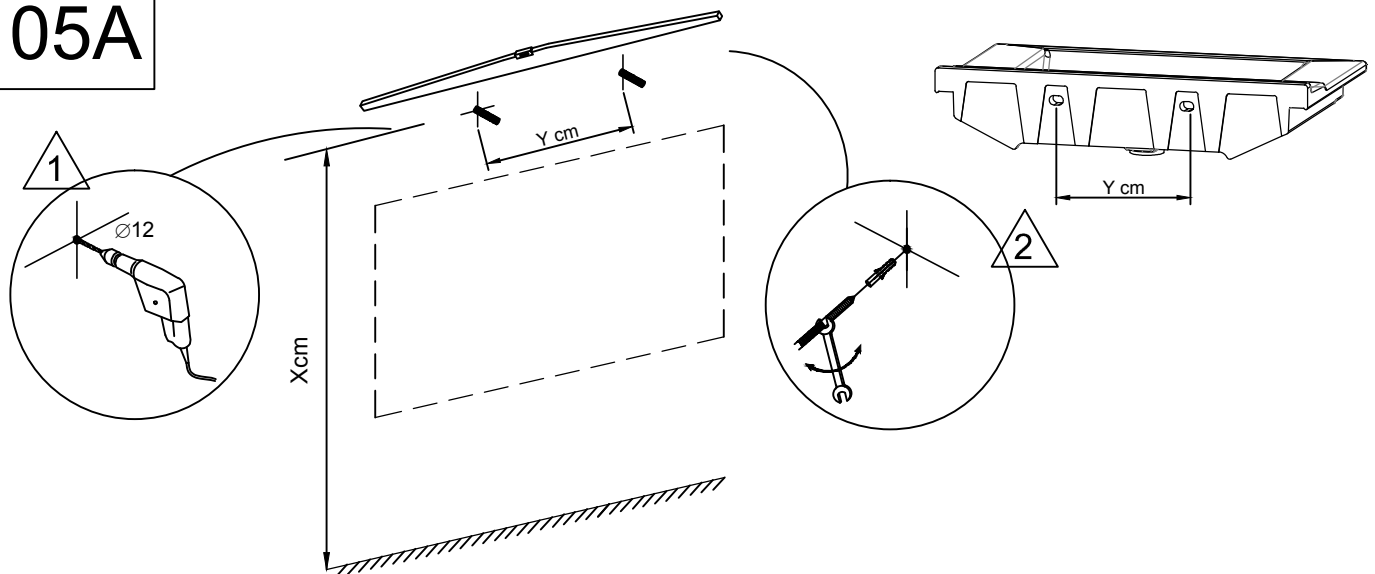

# 06A

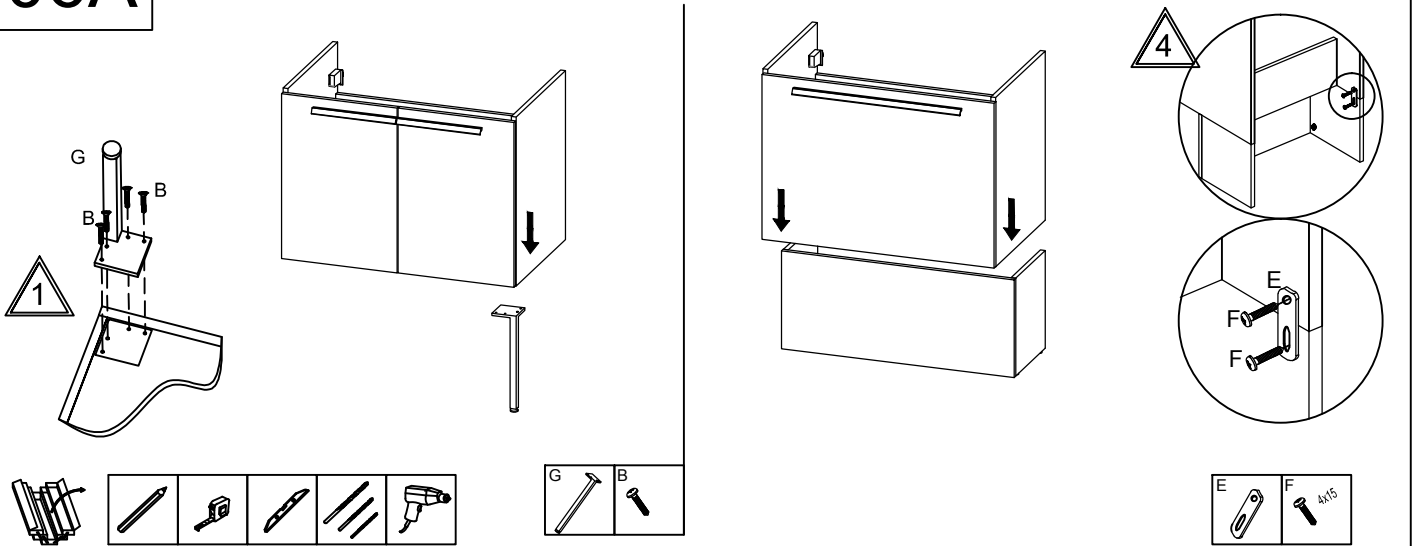

# 07A

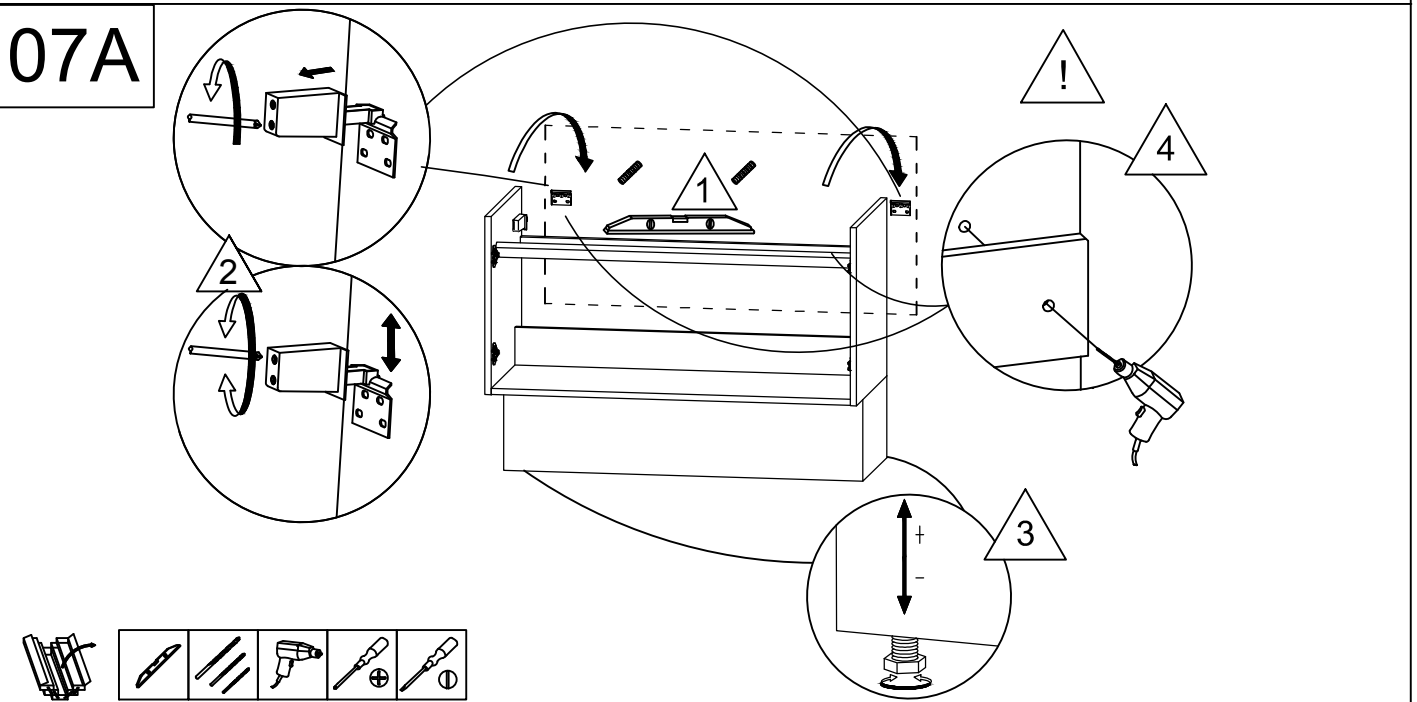

# 08A

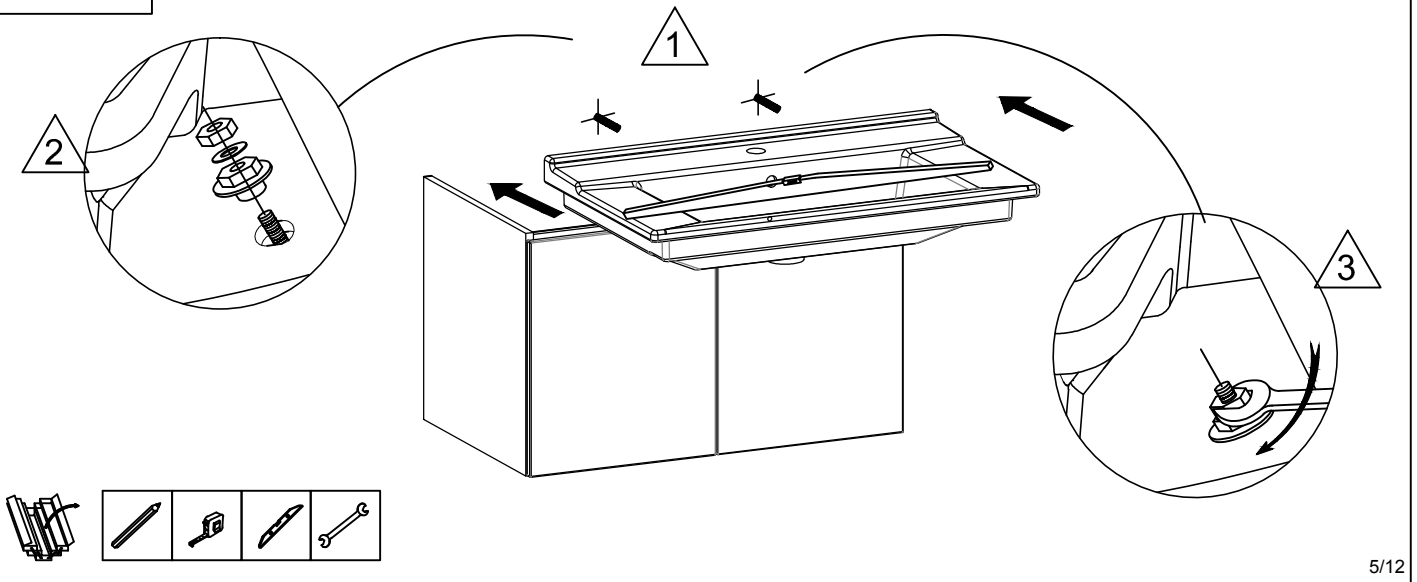

# 09A

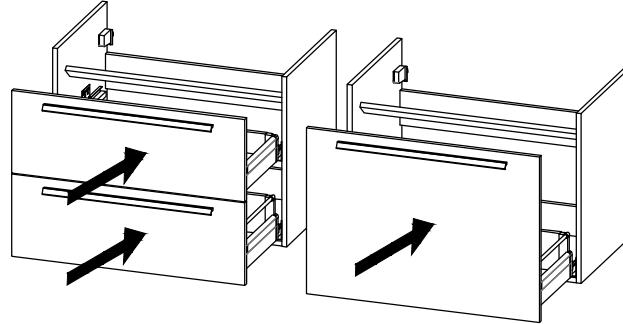
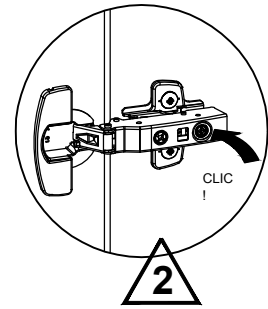
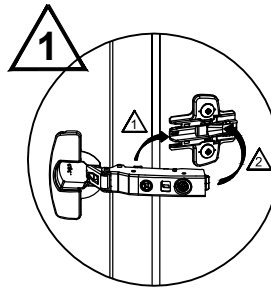
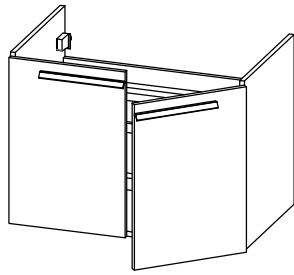

# 10A

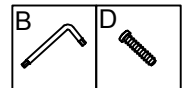
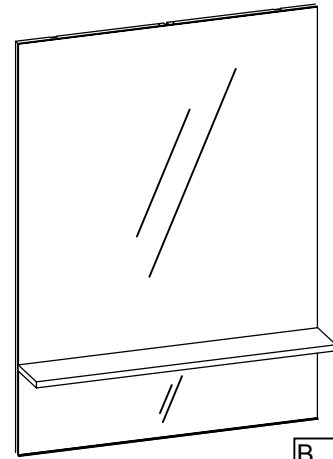
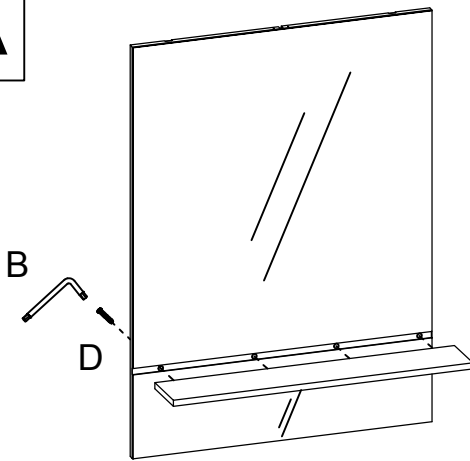

# 11A

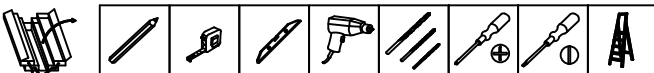
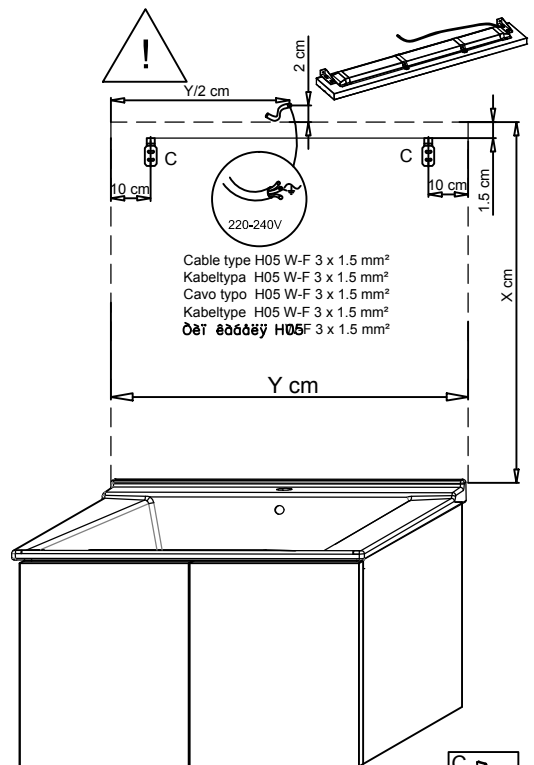
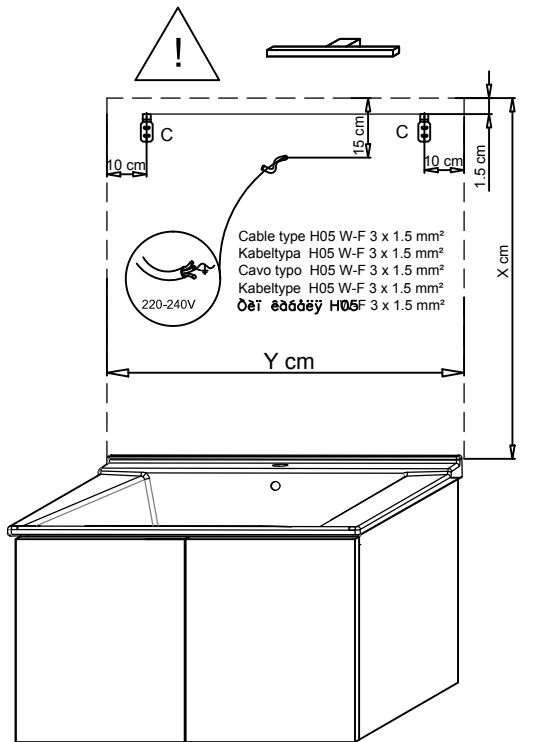
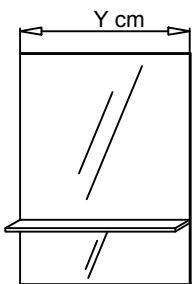

12A

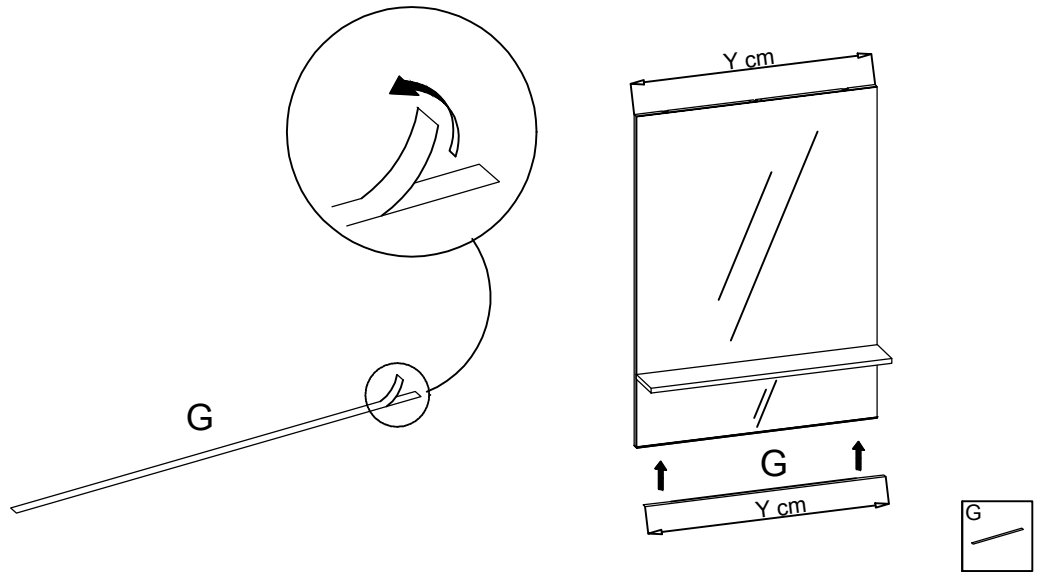

13A

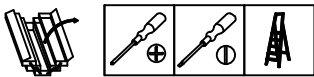
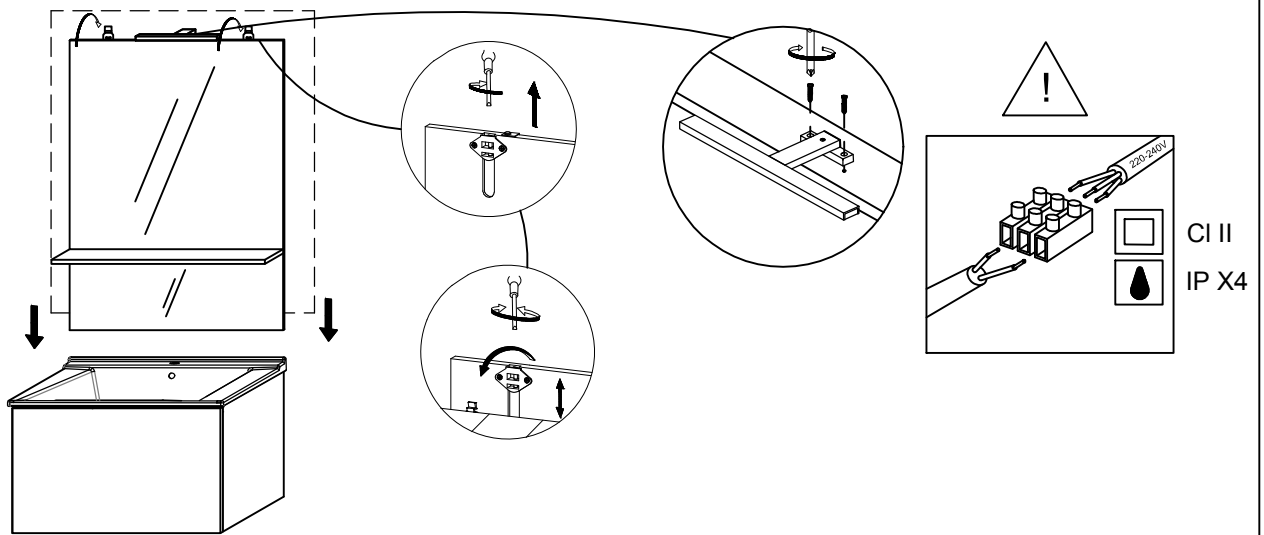

14A

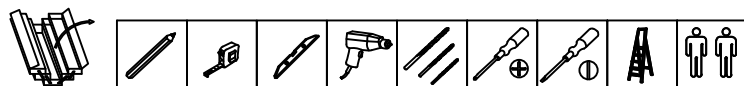
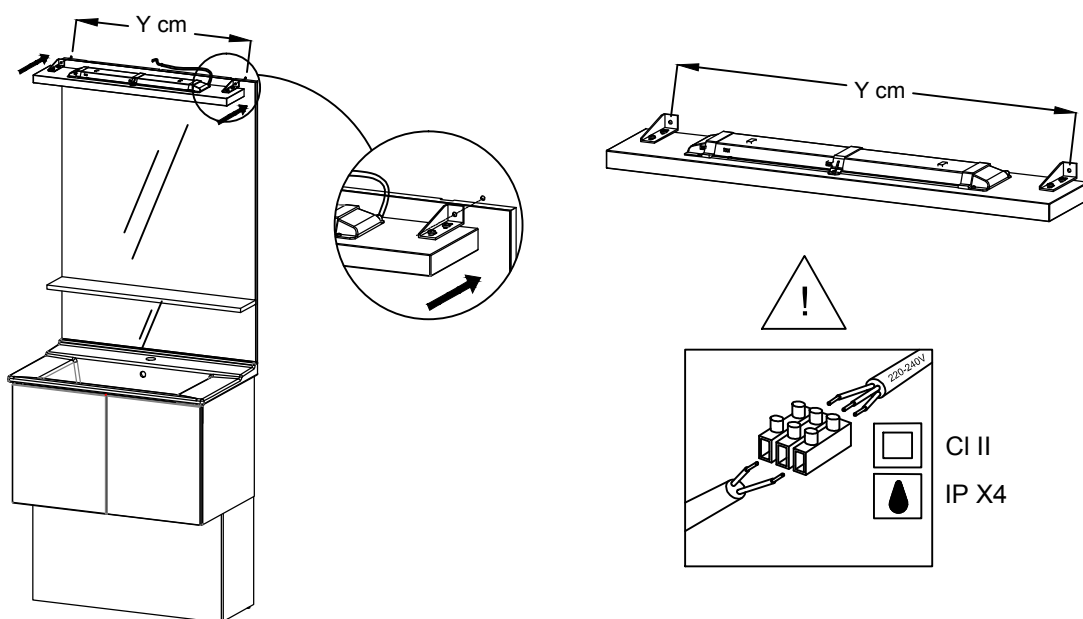

B

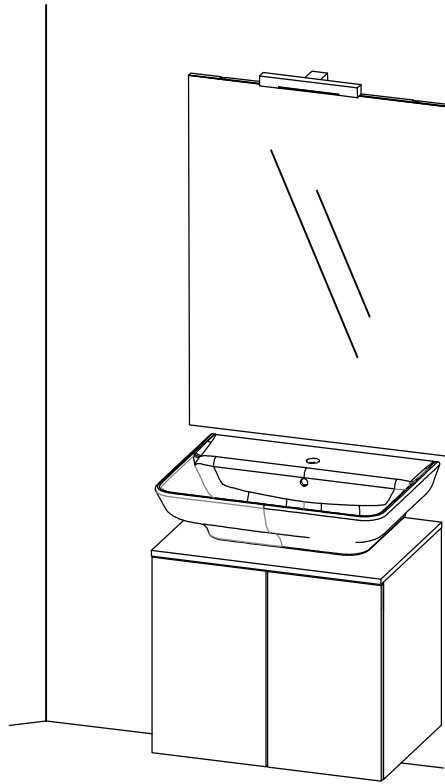

15B

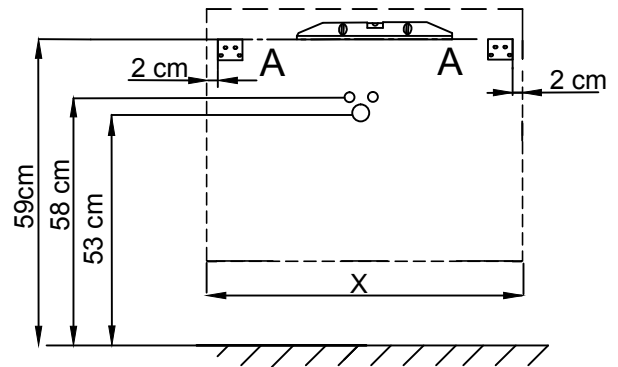
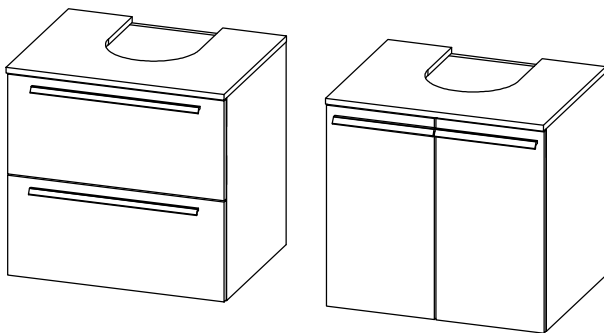

# 16B

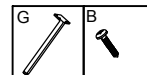
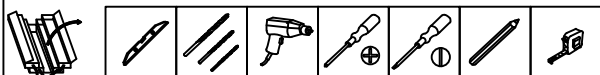
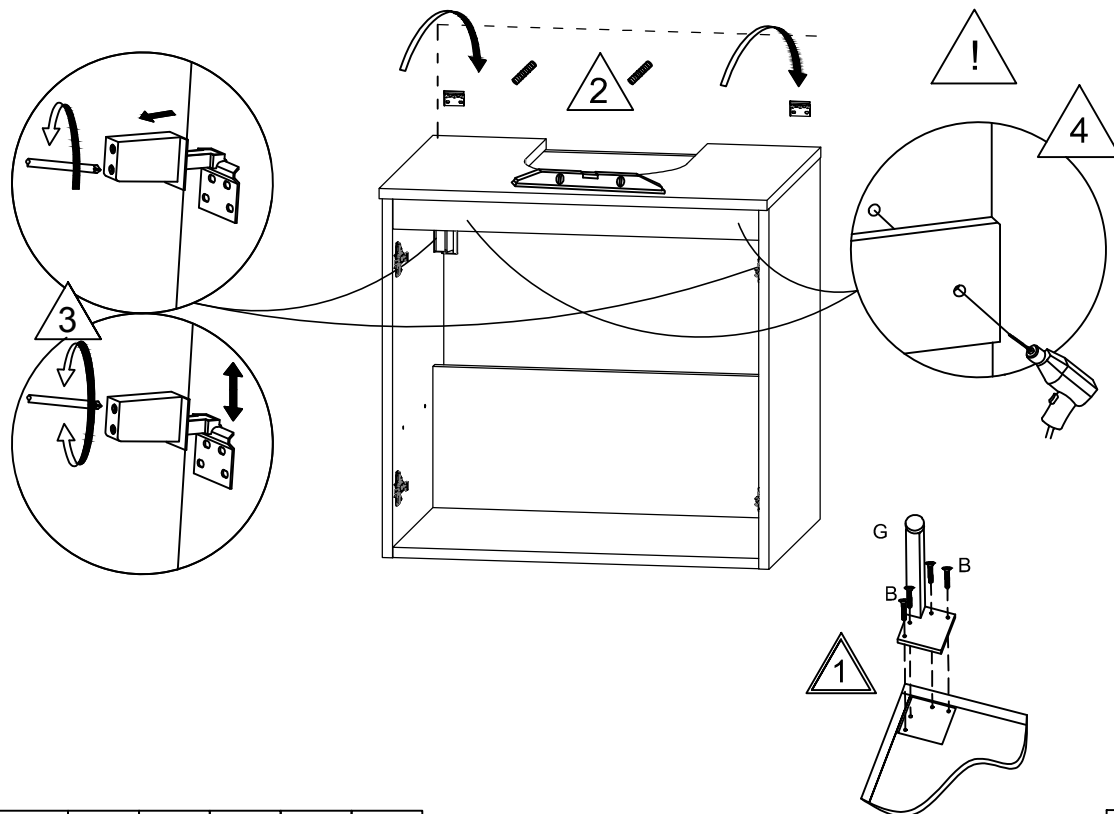

# 17B

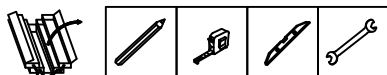
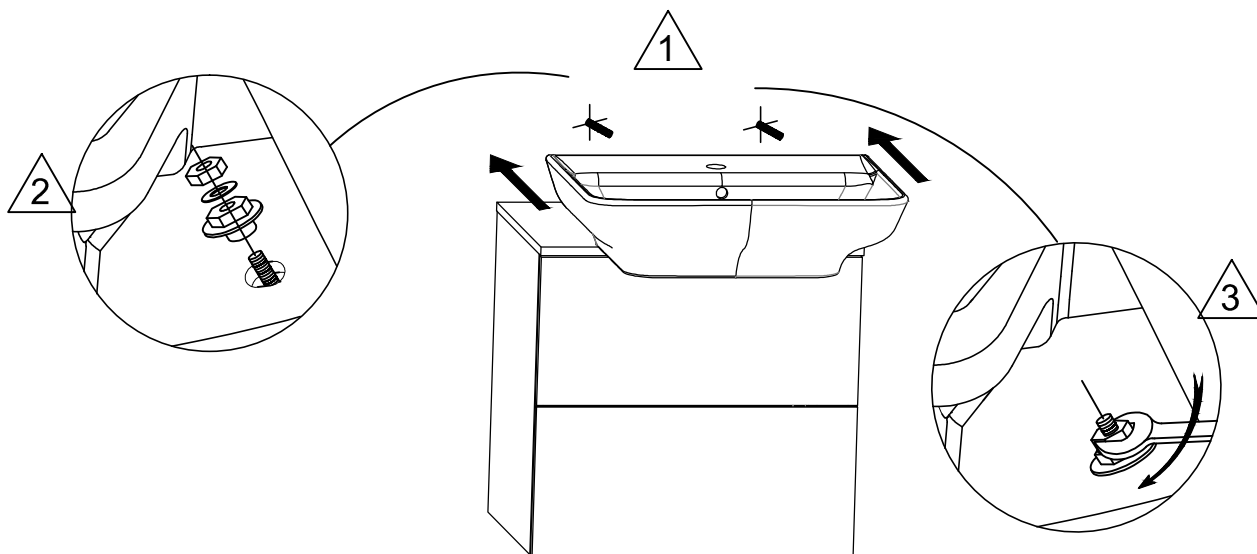

# 18B

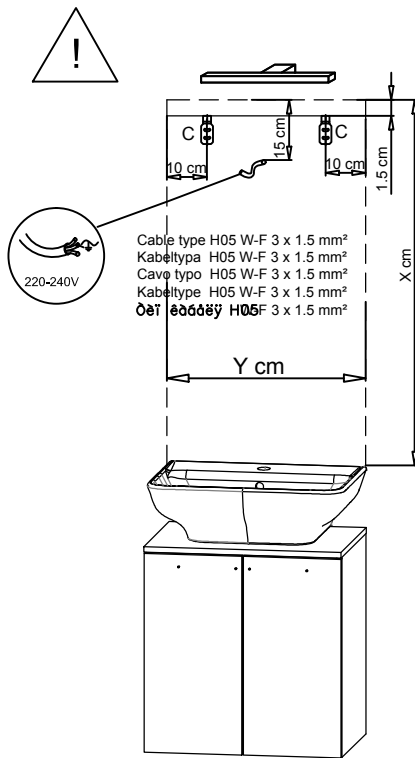
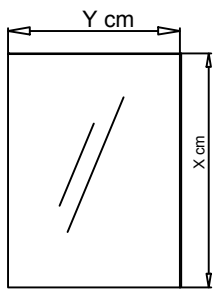

Cable type H05 W-F 3 x 1.5 mm<sup>2</sup>  
 Kábeltypa H05 W-F 3 x 1.5 mm<sup>2</sup>  
 Каго тыпо H05 W-F 3 x 1.5 mm<sup>2</sup>  
 Kábeltype H05 W-F 3 x 1.5 mm<sup>2</sup>  
 Одет кабелёу H05F 3 x 1.5 mm<sup>2</sup>

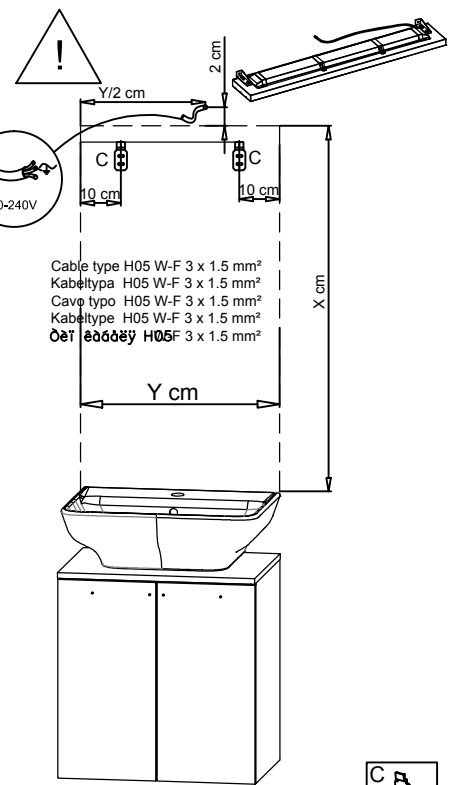
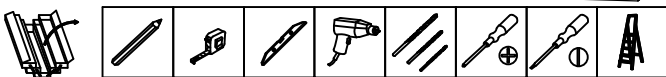

Cable type H05 W-F 3 x 1.5 mm<sup>2</sup>  
 Kábeltypa H05 W-F 3 x 1.5 mm<sup>2</sup>  
 Каго тыпо H05 W-F 3 x 1.5 mm<sup>2</sup>  
 Kábeltype H05 W-F 3 x 1.5 mm<sup>2</sup>  
 Одет кабелёу H05F 3 x 1.5 mm<sup>2</sup>



# 19B

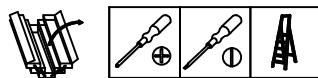
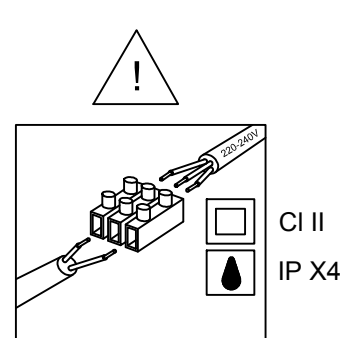
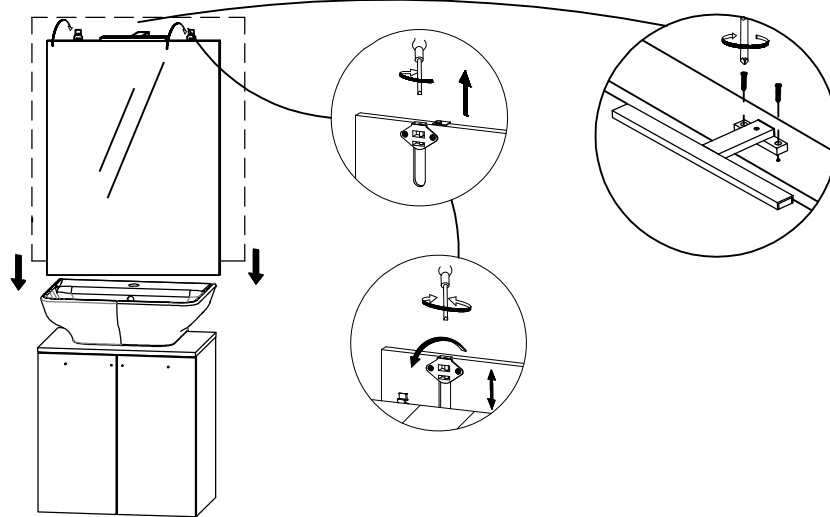

# 20B

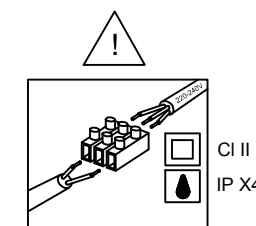
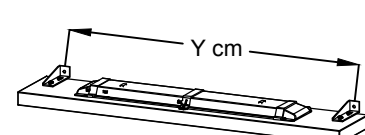
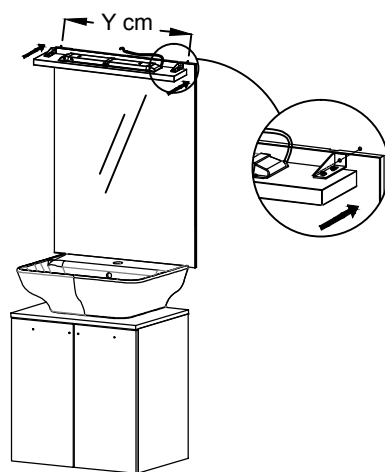

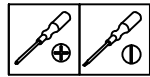
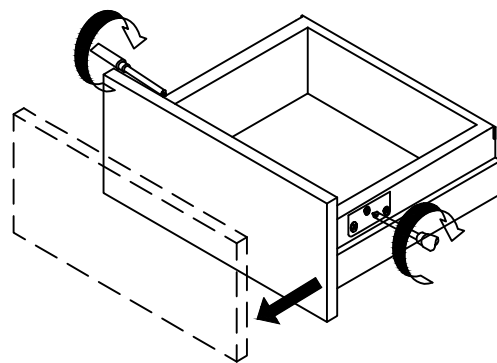
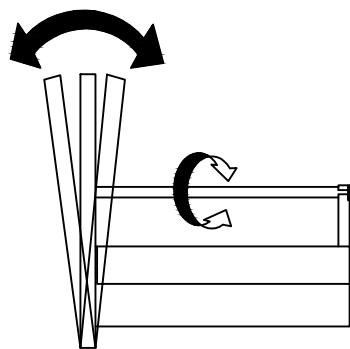
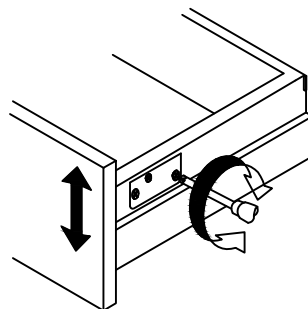
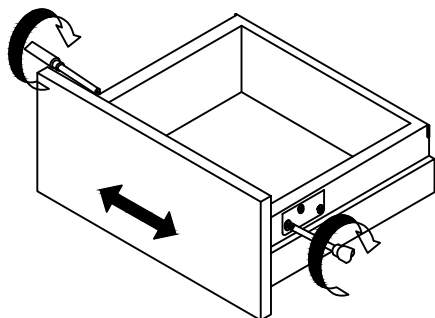
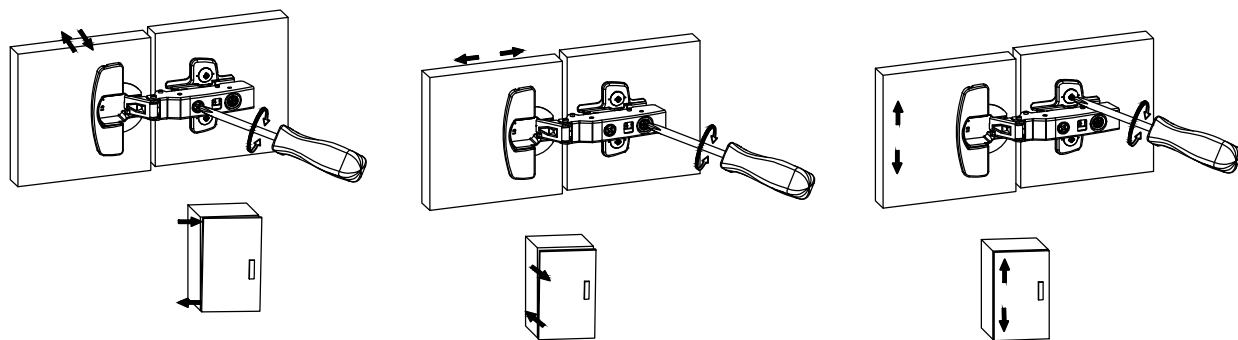

**JACOB DELAFON España**

Ctra. Logroño, km 17  
50629 SOBRADIEL  
ZARAGOZA

<http://www.jacobdelafon.com/es/index.jde>

Tél : +34 902 46 46 86

**KOHLER / JACOB DELAFON**

207, Angle Boulevard d'Anfa  
20 000 CASABLANCA

<http://www.jacobdelafon.com/ma/index.jdf>

Tél : +212 2 295 9740

**KOHLER UK**

Cromwell Road  
Cheltenham  
GL525EP Gloucestershire  
UNITED KINGDOM

<http://www.kohler.co.uk>

Tél : +44 (0)844 571 0048

**KOHLER ITALIA KITCHEN AND BATH srl**

via Roma 108  
centro direzionale Cassina Plaza  
edificio B - scala 2  
20060 Cassina de Pecchi (Mi)

<http://www.kohleritalia.it>

Tel : +39 02 94437100

**KOHLER DEUTSCHLAND**

Kohler GmbH  
Holtgrade 30  
45739 Oer-Erkenschwick

[www.kohlerco.de](http://www.kohlerco.de)

Tel: +49 2368 91 87-87

**KOHLER MIDDLE EAST**

Al Thuraya Tower 2  
9th Floor, Office 905

P.O. Box 500431

DIC, Dubai, UAE

<http://www.me.kohler.com/eu/index.htm>

Tél : +971-4-3624650

**КОЛЕР РУС / KOHLER RUS**

Ул. 1-я Бородинская, д.2а  
Офис 147

121059 МОСКВА

РОССИЯ

<http://www.jacobdelafon.ru>

Тел.: +7 495 783 5223